



Briefing Session

Discussion Paper on Concepts for the Introduction of Digital Terrestrial Television Broadcast (DTTB)

***A platform for harnessing media and applications
convergence...***

**June 12, 2003
Dewan Tun Hussein Onn "B"
Putra World Trade Center, Kuala Lumpur**



Agenda

0845-0930hrs : Registration and Coffee/Tea

0930-0945hrs : Opening Remarks

Y.Bhg. Tan Sri Nuraizah Abdul Hamid, Chairman, MCMC

0945-1030hrs : Presentation

Mr. Toh Swee Hoe, Industry Development Division, MCMC

1030-1130hrs : Question and Answer

*Chaired by Y.Bhg. Tan Sri Nuraizah Abdul Hamid,
Chairman, MCMC*

1130hrs : End, Refreshments



What will we cover?

1. Background on CMA and broadcasting market
2. Introduction to Digital Terrestrial Television Broadcasting (DTTB)
3. The DTTB challenges and questions in the Consultation Paper
4. Conclusion



The Discussion Paper

1. Released on April 28, 2003. **Closing date for submission of inputs is June 27, 2003.**
2. The paper highlights issues and approaches in the implementation of DTTB and invites submissions from interested parties. Submissions need not be limited to the questions in the paper.
3. Inputs received shall be considered by the Commission in developing policy recommendations and implementation strategies for DTTB
4. Today's briefing further firms the Commission's commitment to ensure that all concerns and issues are fully discussed and analyzed to ensure the best approach for DTTB



Background on CMA and the broadcasting market

Concepts for the Introduction of DTTB in Malaysia, June 12, 2003



10 National Policy Objectives for the Communications & Multimedia industry under the CMA 1998

1. Creating a global hub
2. Building a civil society
3. Nurturing local content and culture
4. Ensuring long-term benefits for end-users
5. Nurturing user confidence
6. Promoting access and equity

7. Creating a robust applications environment
8. Facilitating efficient allocation of resources
9. Developing industry capabilities
10. Promoting secure and safe networking

NOTE: Abbreviated from Section 3(2) of the Communications and Multimedia Act 1998 (Act 588)

Communications and Multimedia Act (CMA) 1998

A framework to manage/facilitate convergence

Licensing conditions, competition,
access to service

Numbering, Spectrum, Standards

Regulatory Framework

Procedural

Economic
Regulation

Technical
Regulation

Consumer
Protection

Social
Regulation

Transparency

Rates

Service quality standards

Licence conditions

Consumer Codes

Universal service

Concepts for the Introduction of DTTB in Malaysia, June 12, 2003

Content Codes



CMA Licensing Regime

[Four Horizontal Markets in Three categories]

Individual	Class	Exempt
NFP	NFP	NFP
NSP	NSP	NSP
ASP	ASP	ASP
CASP	CASP	CASP



- **Only activities with significant economic or social impact are individually licensed.**
- **The long term objective is to move to less regulation.**

Concepts for the Introduction of DTTB in Malaysia, June 12, 2003



CMA Licensing Environment

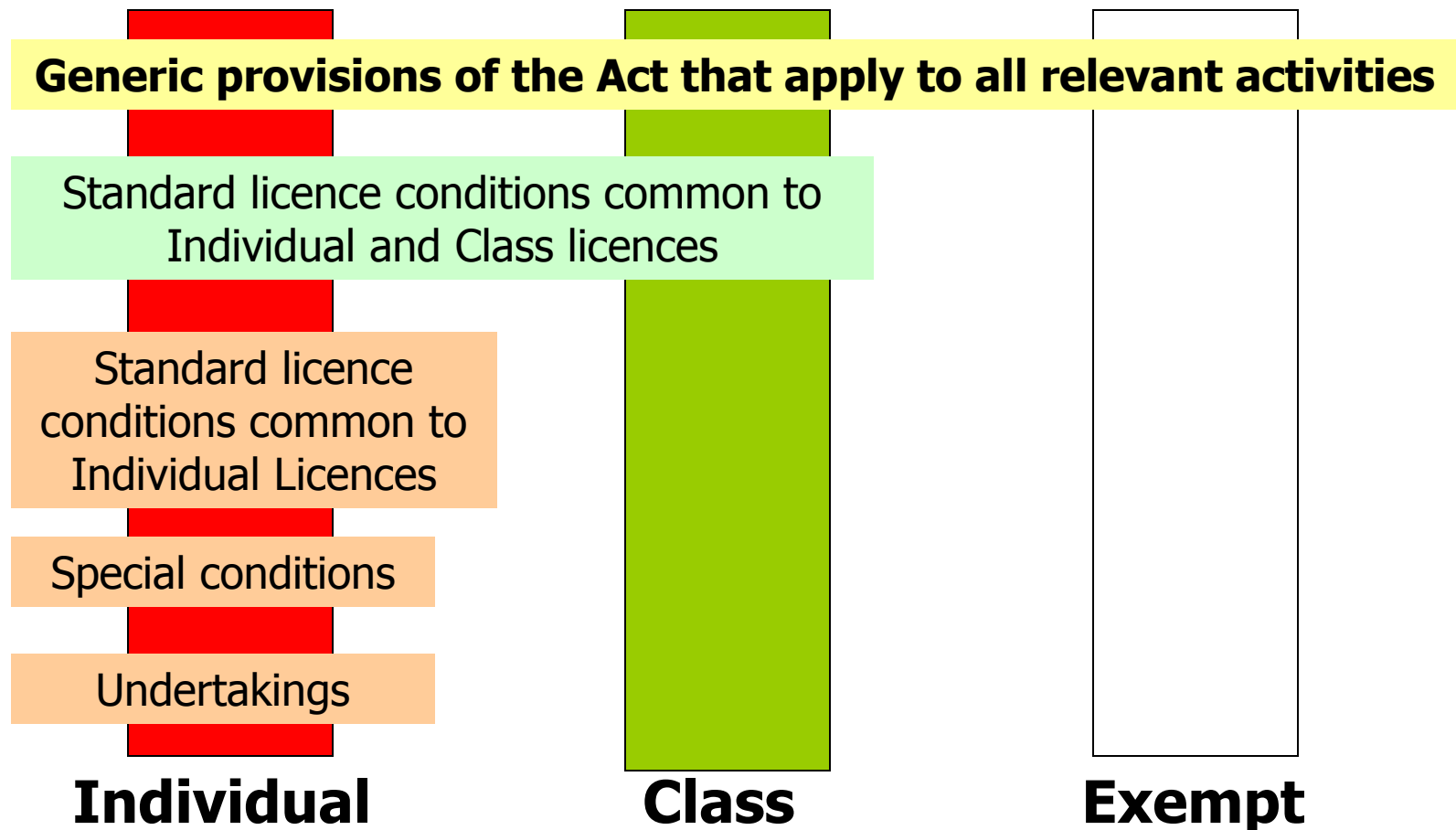

Concepts for the Introduction of DTTB in Malaysia, June 12, 2003



Licensing- Current NFP List

Individual	Class	Exempt
<p>Fixed links and cables Submarine cable landing centre Radio communications transmitters and links Satellite control stations Satellite hubs Space station Earth station Towers, poles, ducts and pits Switching centre Public payphone facilities</p>	<p>Niche or limited purpose network facilities</p>	<p>Broadcasting and production studios Incidental network facilities Internet cross-connect equipment Private network facilities</p>

Concepts for the introduction of DTTB in Malaysia, June 12, 2003



Licensing- Current NSP List

Individual	Class	Exempt
Bandwidth services Broadcasting distribution Cellular mobile Access applications Space services	Niche customer access Niche connection	Incidental network service LAN service Private network service Router internetworking



Licensing- Current ASP List

Individual	Class	Exempt
PSTN Public cellular IP Telephony Public payphone Public switched data	Audiotext hosting Directory Internet access Messaging	Electronic transaction Interactive transaction Networked advertising boards and cineplex Web hosting or client sever

Concepts for the Introduction of DTTB in Malaysia, June 12, 2003



Licensing- Current CASP List

Individual	Class	Exempt
Satellite broadcasting Subscription broadcasting Terrestrial free to air TV Terrestrial radio broadcasting	Minister to decide on services to be registered under ASP Class	Internet content services



CURRENT LICENSING POLICY

Ministerial Direction on General Licensing Policies, Direction No. 3 of 2001

1. Closed basket approach in the **NFP (I)** – licensees can only own and/or provide facilities listed on their licence
2. **CASP (I)** categories - can only provide the services in their licence; Minister's prior approval required to do others; not allowed to provide satellite broadcasting services
3. **No cross-sector** activities - the holder of an **ASP (I)** licence will not be granted a **CASP (I)** licence, vice versa.
4. Open basket approach in the NSP (I) and ASP (I) categories.
5. ASP (I) licences issued only up to 2005



Self regulating mechanism

[Industry Forum Areas of Focus]

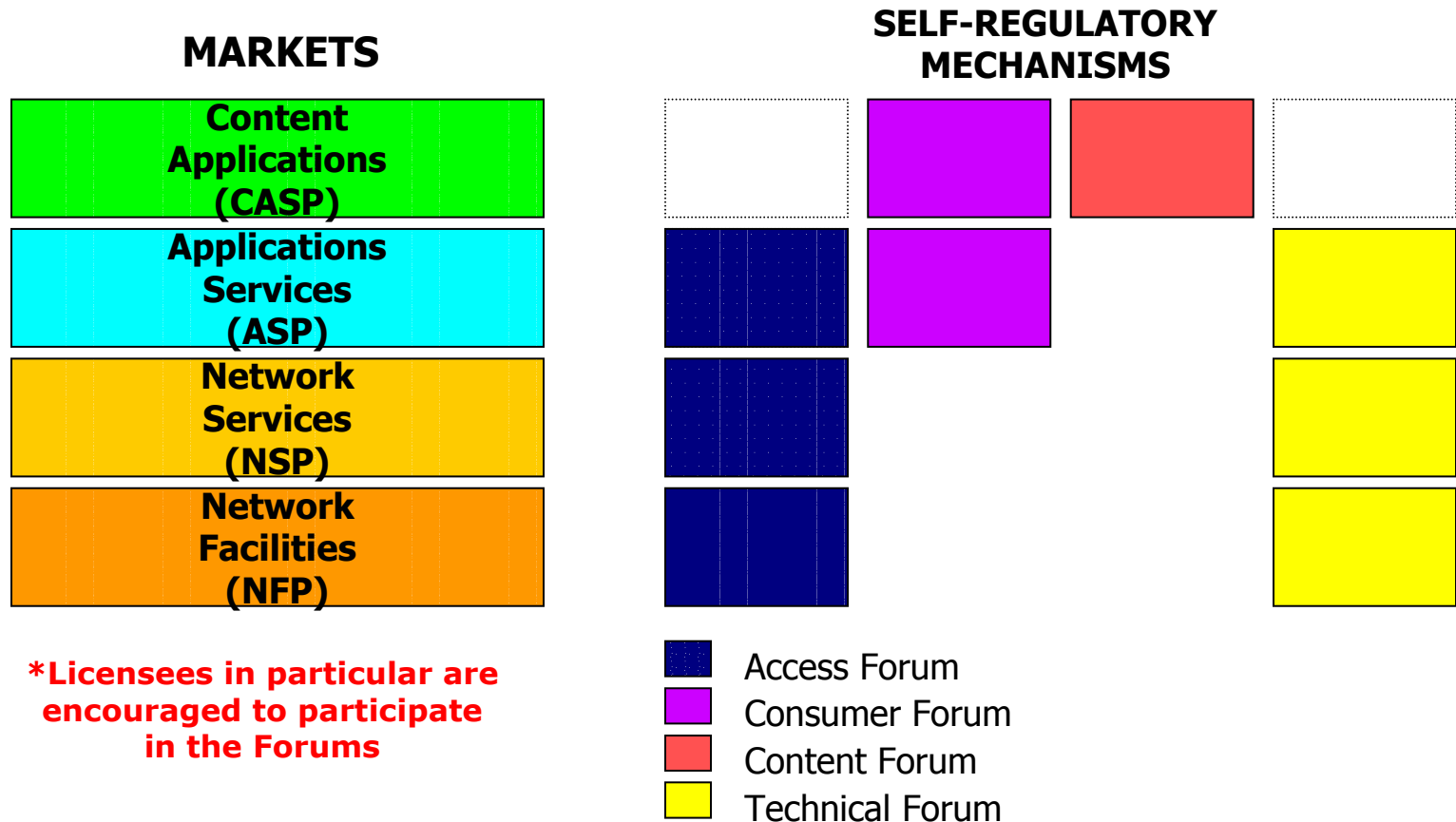

Concepts for the Introduction of DTTB in Malaysia, June 12, 2003



Present Day

1. TV and Radio programme channels are available over **free to air** and **subscription** on **terrestrial** analogue TV and radio as well as on digital transmission over satellite direct to home platform
2. High degree of spectrum congestion and inefficient analogue transmission platform have limited industry development and growth in this area
3. Content providers (broadcasters) i.e. the CASP Individual licensees either own or lease the transmitters and towers from NFP Individual licensees. Distribution links between broadcast transmitters and studios are provided by the NFP Individual licensees
4. Coverage of 95% of population.



Statistics

1. Radio – 3.780 million households *
2. TV – 4.049 million households *
3. Digital satellite subscription TV – 1.001 million subscribers **
4. Broadband access– 19,300 subscribers **
5. Dial up Internet– 7.842 million users**

*The Population and Housing Census 2000, Dept of Statistics Malaysia

**Statistical Bulletin, Q4/2002, Malaysian Communications and Multimedia Commission



19 CASP(I)s, 7 allowed to provide television broadcasting services, 2 of which are operating.

1. Sistem Televisyen Malaysia Berhad	Terrestrial Free to Air TV
2. Natseven TV Sdn. Bhd.	Terrestrial Free to Air TV
3. Metropolitan TV Sdn. Bhd.	Terrestrial Free to Air TV
4. Cableview Services Sdn. Bhd.	Subscription Broadcasting
5. Grafimatix Sdn. Bhd.	Subscription Broadcasting
6. Medanmas Sdn. Bhd.	Terrestrial Free to Air TV
7. Network Guidance Sdn. Bhd.	Subscription Broadcasting
8. Maestra Broadcast Sdn. Bhd.	Terrestrial Radio Broadcasting
9. Measat Radio Communications Sdn. Bhd.	Terrestrial Radio Broadcasting
10. Synchrosound Studios Sdn. Bhd.	Terrestrial Radio Broadcasting
11. Kristal Harta Sdn. Bhd.	Terrestrial Radio Broadcasting
12. Suara Johor Sdn. Bhd.	Terrestrial Radio Broadcasting
13. Radio Rediffusion Sdn. Bhd.	Terrestrial Radio Broadcasting
14. Radio Lebuhraya Sdn. Bhd.	Terrestrial Radio Broadcasting
15. Husa Network Sdn. Bhd.	Terrestrial Radio Broadcasting
16. Institut Kefahaman Islam (IKIM)	Terrestrial Radio Broadcasting
17. Malaysian Airports Sepang Sdn. Bhd.	Terrestrial Radio Broadcasting
18. Rimakmur Sdn. Bhd.	Terrestrial Radio Broadcasting
19. Titian Sebaran Sdn. Bhd.	Terrestrial Radio Broadcasting

Note: ASTRO is a registered licensee. RTM is exempted from having to hold a licence.

Concepts for the Introduction of DTTB in Malaysia, June 12, 2003



Introduction to Digital Terrestrial Television Broadcasting (DTTB)

Concepts for the Introduction of DTTB in Malaysia, June 12, 2003

Broadband Technologies & Services

DTTB – a part of the broadband initiatives

Medium	WIRED		WIRELESS	
Infra-structure	Fibre	DSL over copper	Satellite	Terrestrial
Mode	2-way	1-way	2-way	1-way
Typical Services	Interactive Multimedia services	Satellite DTH	3G	Digital broadcast
	<p>Note: Broadband technologies provides a digital delivery platform to carry low to high speed applications such as interactive multimedia services (TV, radio, Telephony, messaging, etc)</p>		MMDS	
			W-LAN	

Concepts for the Introduction of DTTB in Malaysia, June 12, 2003



Digital Terrestrial Broadcasting

Besides digital TV, it allows **data-casting** at 4.35Mbps(Mobile)
~27Mbps(Fixed) downstream, and may use cellular/PSTN upstream

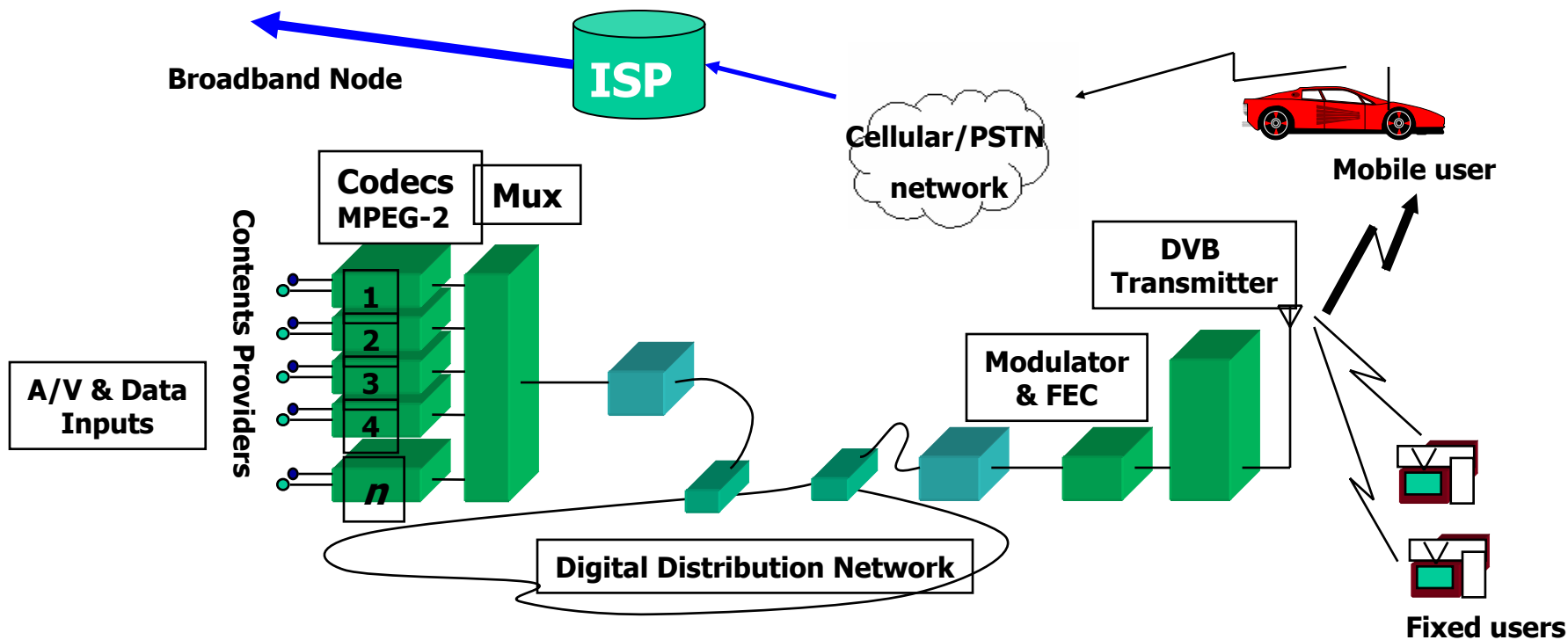

Concepts for the Introduction of DTTB in Malaysia, June 12, 2003



The Implementation of DTTB overseas

Country	Standards adopted	Test/Trials commence	Commercial broadcasts commence	Analogue phase out begins	100% digital TV expected
Malaysia	Recomm. DVB-T	2003-2004	2005	2009?	2014?
Australia	DVB-T	-na-	1 Jan 2001-1 Jan 2004	2009 (analogue shut down)	Review in 2006
Singapore	DVB-T	1998/1999	Dec 2000	-na-	-na-
UK	DVB-T	1997	Nov 1998	2006	2010
USA	ATSC	Pre 97	1999	2005 Ends 2006	As at 5/03, 76%
South Korea	ATSC	2000	2001	2010	2010 or 95% adoption
Taiwan	DVB-T	-na-	End 2002	Before 2006	2008?

Concepts for the Introduction of DTTB in Malaysia, June 12, 2003



Why go digital? Benefits? Opportunities?

Consumer

1. Better viewing experience
2. More channels more opportunities
3. Enhanced services, e.g.

Captioning

Programming guide

Choice of viewing angles

4. New services - new growth e.g.

Internet – option for digital divide

Interactive home shopping

Mobile TV/data

5. Promotes convergence

content + applications

6. Efficient spectrum use



Digital transmission?

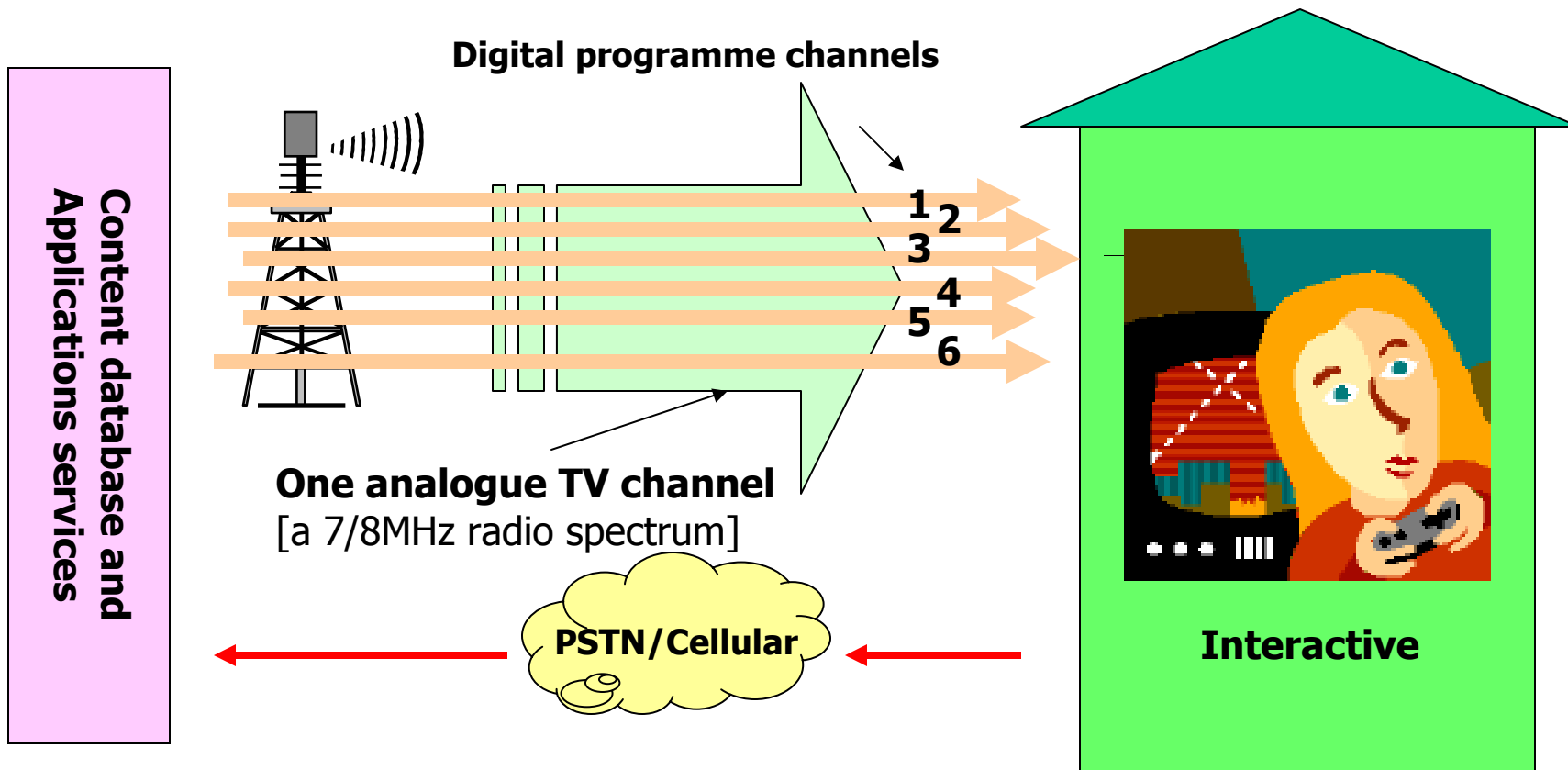



But there are costs to it...

Consumer

Set-top box... RM500x4m?

aerial... RM200x4m?

installation... RM50x4m?

transmitter... RM40m?

studio... RM40m?

transmission... RM40m?

spectrum... RMxxm?

coordination...

others... RMxxm ?

Industry

Govt/Regulator

***Estimated total cost over the migration period of 10 years**



The DTTB Challenges

Concepts for the Introduction of DTTB in Malaysia, June 12, 2003



The three key challenges

1. Providing quality coverage
2. Providing digital services
3. Managing the transition to digital services



DTTB – Challenge No. 1

1. Providing Quality Coverage (Questions C, D, E, F, G, H)

- a. Spectrum management
 - i. Planning to optimize the use of the available spectrum
 - ii. Network – Single (SFN) and/or Multiple (MFN) Frequency Network?
 - iii. Method of assignment of spectrum, its cost, and to who?
- b. Roll out
 - i. How to leverage on existing infrastructure, what capacity or number of channels and the timeline to achieve similar or better coverage than existing analogue system



Spectrum Management – under CMA 1998

Spectrum - The airwaves between DTTB transmitters and set-top boxes or the last mile connectivity

1. The MCMC is tasked with the responsibility to manage spectrum
2. The MCMC has developed a Spectrum Plan (final draft) that allocates frequency bands to radio communication services
3. CMA subsidiary legislation - Communications and Multimedia (Spectrum) Regulations 2000 has been issued to provide a transparent process for managing issuance of these assignments
4. Unless exempted by the Minister, to use spectrum [], a person needs to hold either a:-
 - a. Spectrum,
 - b. Apparatus or
 - c. Class assignment



Spectrum Management - Types of assignment

1. Class Assignment

Authorizes the use by any person of a device with a specified frequency band for a specified purpose. No fees payable and valid until canceled by the Commission.

Some examples are: cellular telephones, wireless car security alarm

2. Apparatus Assignment

- a. Authorizes a person to use of operate an apparatus of a specified frequency bands under specified conditions.
- b. An assignment is issued to a person who meets the eligibility criteria and that frequency is available.

Note: CASPs currently holds this type of assignments for their TV and/or Radio transmitters



Spectrum Management – Types of assignment

3. Spectrum Assignment

- a. Confers the **right to use** one or more specified frequency bands consistent with the assignment conditions.
- b. Spectrum can be assigned by way of auction, tender or fixed price
- c. In spectrum assignment, the Minister must issue a Determination for the relevant frequency band.
- d. The MCMC shall then carry out the assignment process by preparing a Marketing Plan and an Applicant Information Package (tender/auction document).
- e. The MCMC then makes its selection of the applicant based upon the criteria set out in the AIP and award the assignment.

Note: A Spectrum Assignment Holder need not be a holder of a Network Facility licence

Concepts for the Introduction of DTTB in Malaysia, June 12, 2003



DTTB Spectrum and Roll out?

1. The frequency bands (TV - Band IV) for DTTB is as specified in the draft **Spectrum Plan**. It is currently used for analogue TV but some (a few channels) unassigned frequency bands has been identified for the DTTB service plan. Will use of Band III save implementation cost?
2. The policy on its assignment to interested parties to be developed to time with the **expected implementation of DTTB by 2005** (see Framework for Industry Development 2002-2006). [Issues - What cost and criteria for the award of assignment? How many assignment holders? How many channels? Timeline for assignment holders to roll out to achieve x% coverage?]



FREQUENCY ALLOCATION

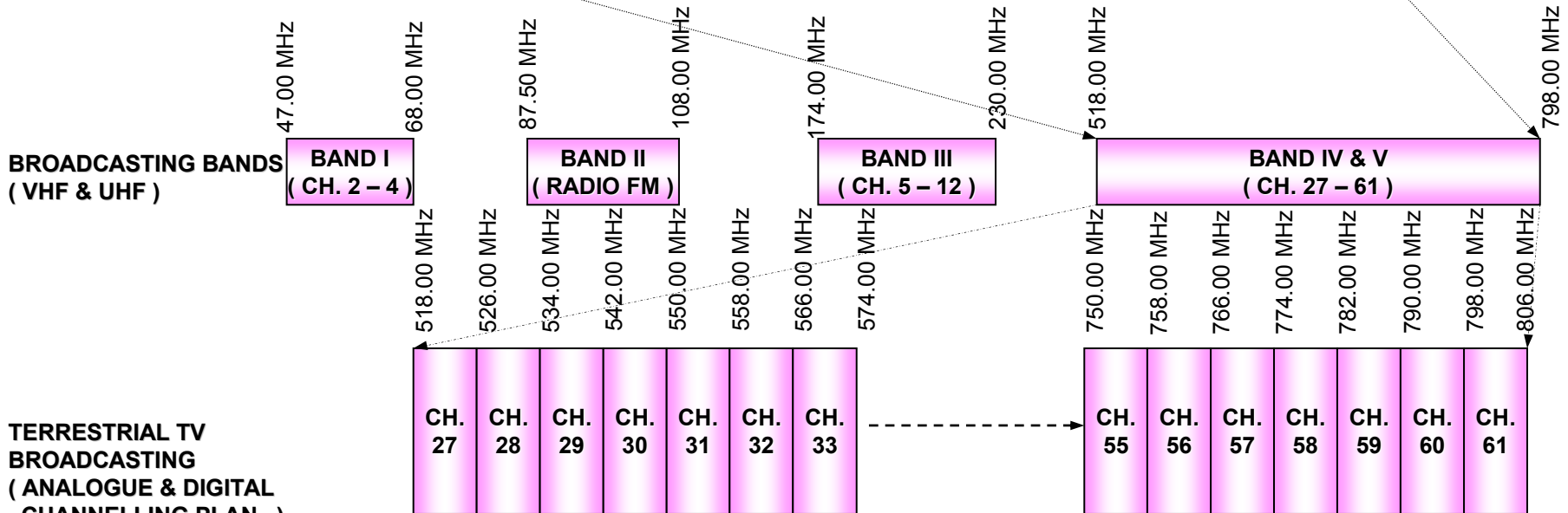
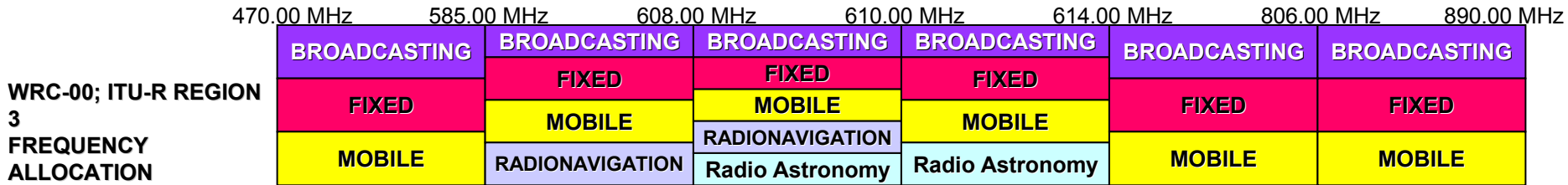

Concepts for the Introduction of DTTB in Malaysia, June 12, 2003



DTTB CHANNEL ALLOCATION – PENINSULAR MALAYSIA

CHANNEL	AREA OF OPERATION	CHANNEL
49	Whole Peninsular Malaysia	SFN
41	Kelantan, Terengganu & Pahang	MFN to cover whole Peninsular Malaysia
42	Perlis, P.Pinang, Kedah, Langkawi, Perak, Selangor, KL, Melaka & N. Sembilan	
48	Johor	
51	Whole Peninsular Malaysia	SFN
43	Kelantan, Terengganu & Pahang	MFN to cover whole Peninsular Malaysia
44	Perlis, P.Pinang, Kedah, Langkawi, Perak, Selangor, KL, Melaka, N. Sembilan & Johor	
57	Whole Peninsular Malaysia	SFN
45	Kelantan, Terengganu & Pahang	MFN to cover whole Peninsular Malaysia
46	Perlis, P.Pinang, Kedah, Langkawi, Perak, Selangor, KL, Melaka, N. Sembilan & Johor	
59	Whole Peninsular Malaysia	SFN
55	Kelantan, Terengganu & Pahang	MFN to cover whole Peninsular Malaysia
61	Perlis, P.Pinang, Kedah, Langkawi, Perak, Selangor, KL, Melaka, N. Sembilan & Johor	
27, 28, 32, 33 & 34	Selangor & KL	SFN



DTTB CHANNEL ALLOCATION – SABAH & SARAWAK

CHANNEL	AREA OF OPERATION	CHANNEL
27, 31, 33 & 39	Sabah	SFN
29, 31, 33, 39 & 41	Sarawak	SFN
29, 41, 49 & 53	Sabah	Sub-regional Coverage area
27, 57, 59 & 61	Sarawak	Sub-regional coverage area



DTTB – Challenge No. 2

2. Providing Digital Services (Questions A, B, I, J, K, L, M, N, O)

- a. Services offered – SDTV, HDTV, radio, number of channels, mobile, interactive, free and/or subscribed?
- b. Service quality and choice to the consumer
 - i. More/new channels and new services, better viewing experience
- c. Convergence
 - i. Promote new business models
 - ii. Development of digital content and applications
- d. Affordable set-top boxes



New Services and Opportunities?

1. Delivery
 - a. SDTV and HDTV?
 - b. Fixed? Portable? Mobile?
2. Business
 - a. Free-to-air and/or subscription (and pay-per-view)?
 - b. Traditional TV, enhanced TV, or interactive TV?
 - c. Applications services such as:-
 - i. Internet access
 - ii. Home shopping, banking
 - iii. Telemedicine
 - iv. Interactive education
 - v. Messaging
 - vi. Access to databases
 - vii. Games
3. Converged services – blending of content + applications creating new services

Concepts for the Introduction of DTTB in Malaysia, June 12, 2003



DTTB service – under the CMA

1. The CMA Licensing framework being technology neutral means that **no new licences are required** to provide the new digital DTTB services
2. The existing CASPs – may provide digital content, and the ASPs may provide applications services on the DTTB platform
3. A Licensee with both the NFP(I) and NSP(I) may own and provide the DTTB multiplexers, the transmitters and links to carry content of CASPs and/or applications services. He only need to get access to the DTTB spectrum.



DTTB Environment under CMA 1998

Multiple service providers supported on a Network

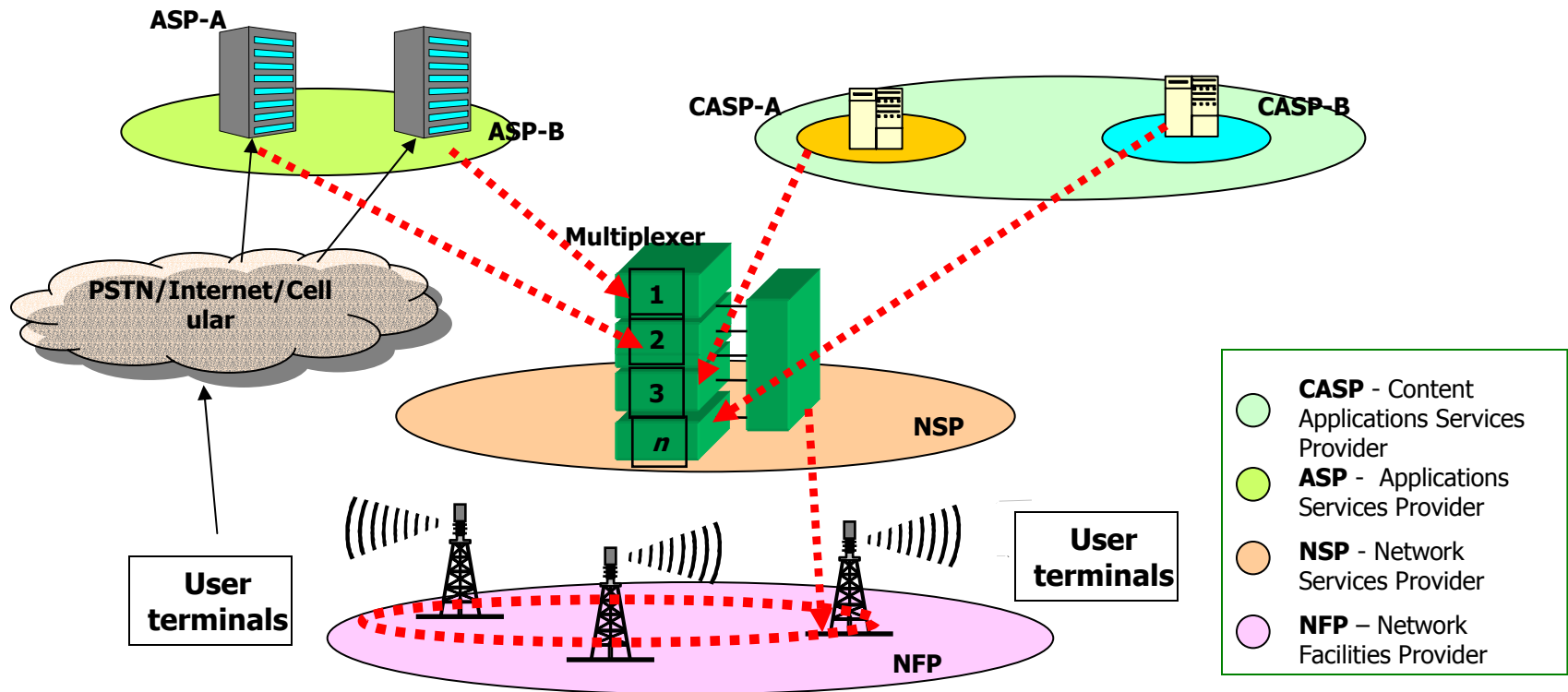

Discussion Paper : Table 3, page 11



Harnessing the DTTB Service Value Chain

Digital television broadcast

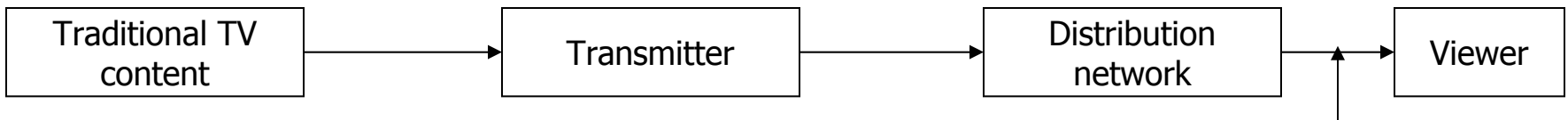
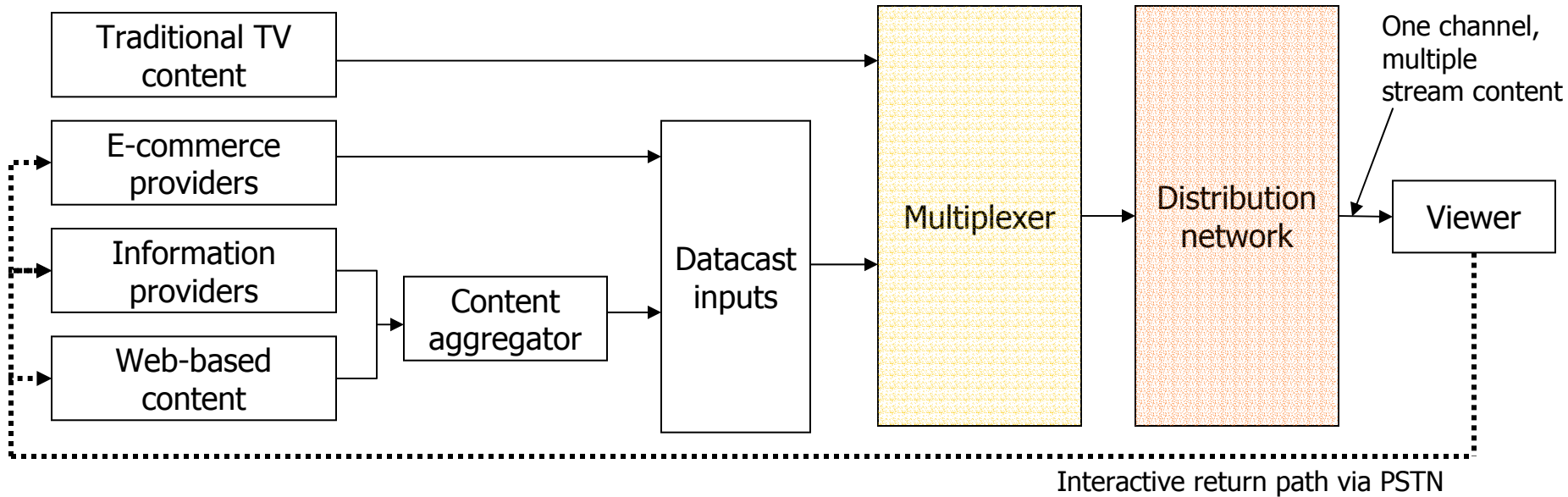

Traditional television broadcast

Concepts for the Introduction of DTTB in Malaysia, June 12, 2003



Free-to-air and Conditional access system?

1. Free to air – accessible by anyone without subscribing or paying any subscription fee
2. Conditional access system allows:
 - a. subscription control
 - b. delivery of specific content to specific targets
 - c. content control
3. Set-top box be just free-to-air and/or may allow both



DTTB – Challenge No. 3

3. Managing digital transition (Questions P, Q, R, S)

- a. Competition and consumer issues
 - i. Common standard – transmission, set-top box, applications, program guide, etc
 - ii. Simulcasting and analogue shutdown
 - iii. Affordability, quality of service and access
- b. Develop action plans to manage the transition
 - i. Consumer education
 - ii. Building capacity to leverage from the digital opportunities



Competition and consumer issues

Promoting competition through common standards

1. open access
2. mass volume → lower cost to consumers
3. large capacity of content and applications developers → digital services

Standards Development – DTTB transmission and Set-Top Box

1. Involves preparation/development of Technical Codes for registration with MCMC
2. MCMC may designate a Technical Standards Forum to do develop these codes. Forum not yet designated
3. In the meantime, IWG for specific areas has been formed. IWG for DTTB was formed in 1999 and has completed its recommendations on the choice of standards (DVB-T) to the MCMC. Further work needed in the set-top box area once the standard is registered

Concepts for the Introduction of DTTB in Malaysia, June 12, 2003



Processes in the adoption of standards

1. MCMC recommends to Minister on the standards based on IWG
2. Minister may direct MCMC to determine an Mandatory standard (MS) for DTTB.
3. MCMC conducts a PI to determine the MS standard from the sets of standards recommended by the relevant world standards body such as ATSC, ISDB, and DVB-T.
4. MCMC analyses comments/inputs and determines the MS standard after consideration of all inputs.
5. IWG continues to develop further details on the standards including requirements in the set-top boxes



Issue on Set Top Boxes

Set-top box technical standards?

1. To promote network interoperability, and
2. To promote public safety

Note : Common standards important for mass market volume leading to affordability and availability as well as access to competitive content and applications

1. > 4 million set-top box and accessories!
2. Concern on its affordability and availability!
3. What strategy shall we adopt?



Issue of simulcasting?

1. Simulcasting – to maintain the availability of the existing programmes on the analogue transmission and at the same time transmitting over the new digital transmission. Aim at minimum disruption of free to air services to consumers
2. Timeline or period of simulcast– duplication of infrastructure - cost to industry
3. Factors affecting timeline
 - a. Rate of rolling out of coverage
 - b. Take up digital service - availability and affordability of set-top boxes

*** Analogue service will begin to be phased out in 2009 or earlier?**



Issue of Proposed Timeline (Question T)

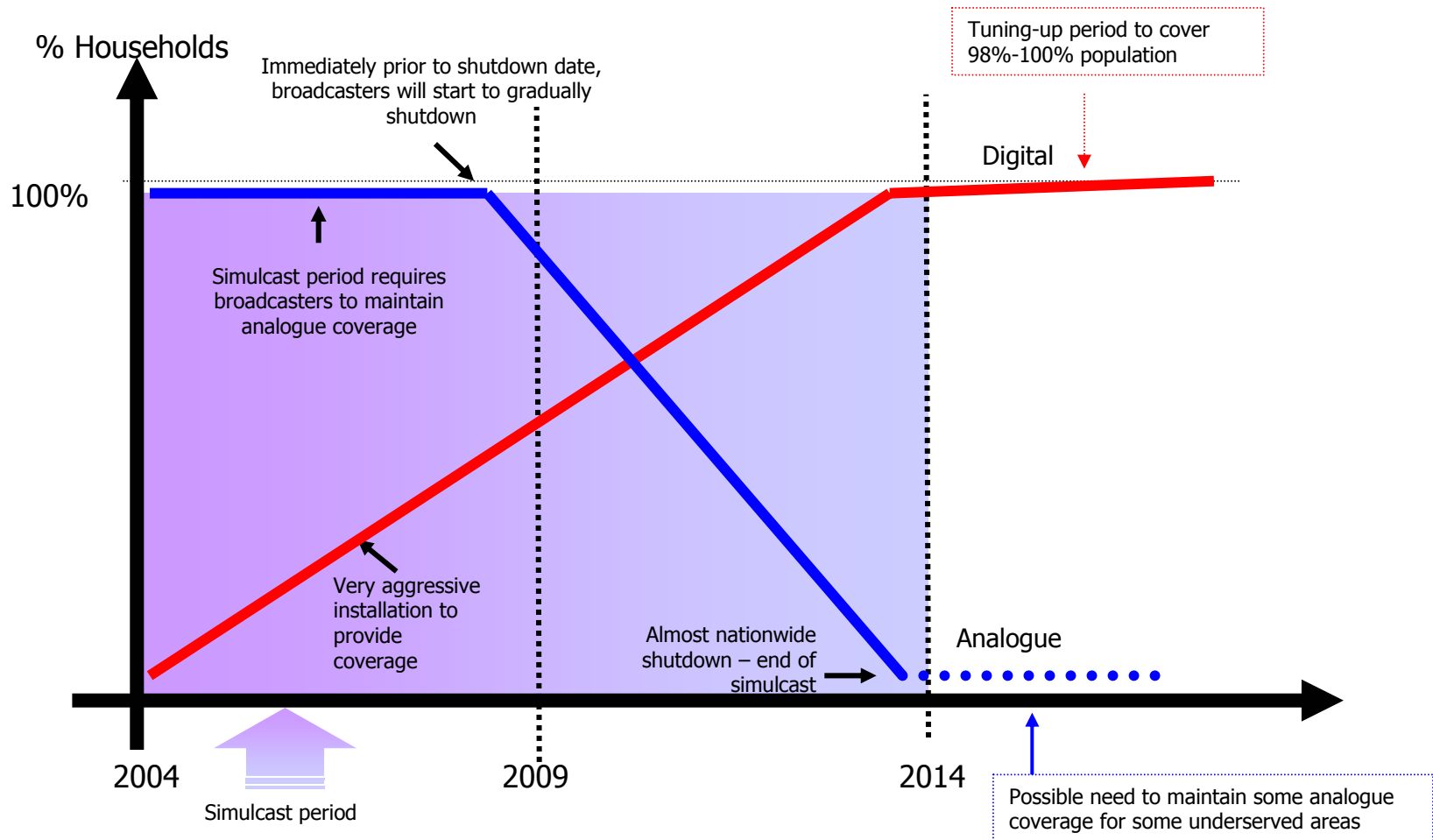

Concepts for the Introduction of DTTB in Malaysia, June 12, 2003



Action Plans?

1. Consumer issues
 - a. Awareness and Education
2. Capacity building -> digital services Malaysian like
 - a. Applications development, and
 - b. Digital content



In conclusion



Keys to DTTB success?

1. Providing quality coverage
 - a. time frame of roll out to achieve good coverage, and
 - b. high investment required – looking for most efficient rolled out, reducing cost by infrastructure sharing, etc
2. Providing digital services -> Malaysians like?
 - a. digital content (number, variety and quality), and
 - b. applications services
3. Planning for migration and adoption digital service
 - a. Set top box penetration cost and take up, and
 - b. Issue of standards for interoperability and competition
 - c. Industry and consumer readiness to harness the opportunities



Keys to DTTB success?

Timelines....

2003 - DTTB trials...

2005 - Commercial DTTB service?

2009 – Start of analogue TV shutdown?



Submissions to be in before 12.00noon, FRIDAY, June 27, 2003 to :

Malaysian Communications and Multimedia Commission
Level 11, Menara Dato' Onn
Putra World Trade Center (PWTC)
45 Jalan Tun Ismail
50480 KUALA LUMPUR

Fax : 03 2693 4881
Email : dttb@cmc.gov.my

THANK YOU.



Q & A



Additional spectrum information



NEW BAND PLAN IN THE BROADCASTING SERVICE

FREQUENCY RANGE (MHz)	BROADCASTING BAND	CHANNEL	NEW SERVICE	USER
47.00 – 68.00	Band I	2 - 4	Mobile & Fixed Service	MINDEF
87.50 – 108.00	Band II	-	Broadcasting (unchanged)	Broadcaster
174.00 – 230.00	Band III	5 - 12	Broadcasting (unchanged)	Broadcaster
470.00 – 518.00	Band IV	21 - 26	Mobile Service	Public & Private Operator
798.00 – 806.00	Band V	62	Fixed Service	MINDEF









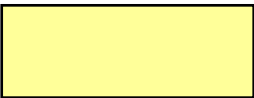

CURRENT ANALOGUE TV AND CHANNELING PLAN FOR DTTB – PENINSULAR MALAYSIA

TV Channel		2	3	4	5	6	7	8	9	10	11	12	21	22	23	24	25	26	27	28	29	30	31	32	33	34	35	36	37	38	39	40	41	42	43	44	45	46	47	48	49	50	51	52	53	54	55	56	57	58	59	60	61	62									
THAILAND																																																															
REGIONAL	Jeli																							R1	R1	R2	R2																																				
	Telipot																							T3																																							
	Peringat																							R1																																							
	Bt. Batu Melinjau																							R1	R2	T3																																					
	Bt. Bakar																							R1	R2																																						
	Paloh																							R1	R2																																						
	Bt. Chupak																							R1	R2																																						
	Tmn. Wangi, GM																							R1	R2																																						
	Bt. Bintang																							R1	R2	T3																																					
	Bt. Besar																							R1	R2	N7																																					
	Kg. Durian Mas																							R1	R2	T3	N7																																				
	Bt. Bauk																							R1	R2	T3	N7																																				
	Bt. Istana																							R1	R2	T3	N7																																				
	Sg. Lembing																							R1	R2	T3	N7																																				
	Bt. Pelindong																							R1	R2	T3	N7																																				
	Kangar																							R1	R2	N7	T3	R1	R2																																		
	G. Raya																							R1	R2	N7	T3	R1	R2																																		
	Kuah																							R1	R2	N7	R3	T3	R1	R2																																	
	Bt. Palong																							R1	R2	N7	R3	T3	R1	R2																																	
	Sintok																							R1	R2	N7	R3	T3	R1	R2																																	
	Pedu																							R1	R2	N7	R3	T3	R1	R2																																	
	Sik																							R1	R2	N7	R3	T3	R1	R2																																	
	G. Jerai																							R1	R2	N7	R3	T3	R1	R2																																	
	Grik																							R1	R2	N7	R3	T3	R1	R2																																	
	Penara																							R1	R2	N7	R3	T3	R1	R2																																	
	Teluk Kumbar																							R1	R2	N7	R3	T3	R1	R2																																	
	Bt. Larut																							R1	R2	N7	R3	T3	R1	R2																																	
	G. Kledang																							R1	R2	N7	R3	T3	R1	R2																																	
	Bt. Kebun Teh																							R1	R2	N7	R3	T3	R1	R2																																	
	G. Brinchang																							R1	R2	N7	R3	T3	R1	R2																																	
	Jor Camp																							R1	R2	N7	R3	T3	R1	R2																																	
	Lumut																							R1	R2	N7	R3	T3	R1	R2																																	
	Chgkt. Rembian																							R1	R2	N7	R3	T3	R1	R2																																	
Bt. Fraser																							R1	R2	N7	R3	T3	R1	R2																																		
G. Ulu Kali																							R1	R2	N7	R3	T3	R1	R2																																		
Menara KL																							R1	R2	N7	R3	T3	R1	R2																																		
Bt. Besi																							R1	R2	N7	R3	T3	R1	R2																																		
Bt. Sembilan																							R1	R2	N7	R3	T3	R1	R2																																		
Ulu Langat																							R1	R2	N7	R3	T3	R1	R2																																		
Damak																							R1	R2	N7	R3	T3	R1	R2																																		
Bt. Telapa Burok																							R1	R2	N7	R3	T3	R1	R2																																		
PD																							R1	R2	N7	R3	T3	R1	R2																																		
Bt. Kayu Ara																							R1	R2	N7	R3	T3	R1	R2																																		
Bt. Tampin																							R1	R2	N7	R3	T3	R1	R2																																		
G. Ledang																							R1	R2	N7	R3	T3	R1	R2																																		
Bt. Tinggi																							R1	R2	N7	R3	T3	R1	R2																																		
G. Pulai																							R1	R2	N7	R3	T3	R1	R2																																		
Penawar																							R1	R2	N7	R3	T3	R1	R2																																		
SINGAPORE																																																															
TV Channel		2	3	4	5	6	7	8	9	10	11	12	21	22	23	24	25	26	27	28	29	30	31	32	33	34	35	36	37	38	39	40	41	42	43	44	45	46	47	48	49	50	51	52	53	54	55	56	57	58	59	60	61	62									



LEGEND :

-  Regional area (existing transmitter station at each state)
-  Existing Analogue Channel (on air)
-  Channel replacement (existing station in Band I and channel 21 – 26) / new assignment(not on air)
-  Channel to be vacated (Plan for MINDEF)
-  Channel to be vacated (Plan for Mobile Service)
-  DTTB Channel (SFN)
-  DTTB Channel (MFN)
-  Analogue Channel Plan (not assigned yet)