

New Jersey State House

Activity Book

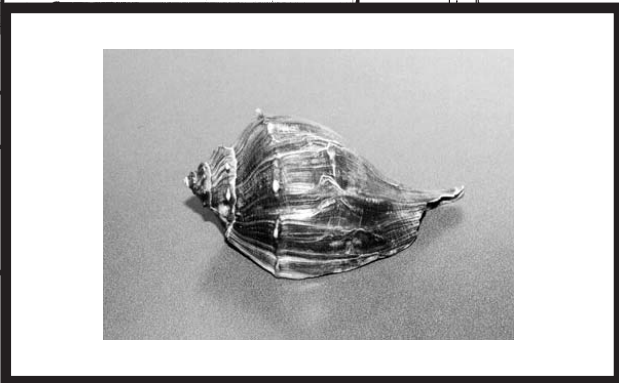

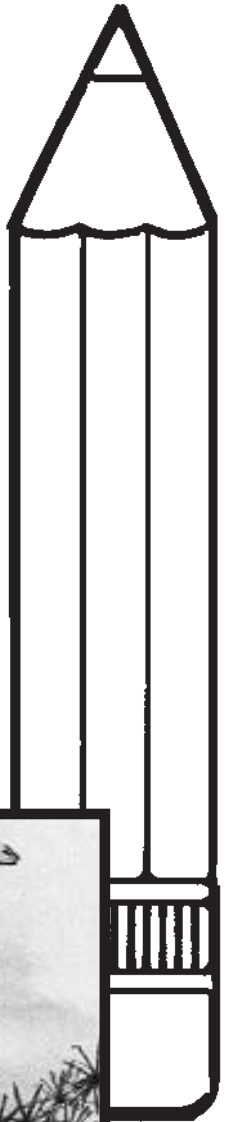
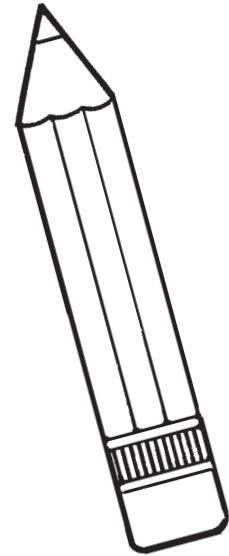
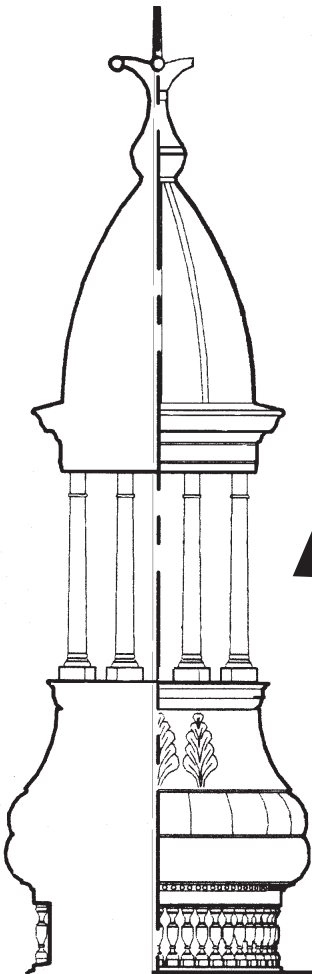

"Hi Kids! My name is Bill. What's your name?"

Fill in the information below and join me in learning about a very special building – our state capitol! Find out what happens here and how a bill becomes a law.

Discover fun facts and play games while you learn.

Best of all, find out ways you can play a part in government!"

My Activity Book

This book belongs to:

Name of my school: _____

My teacher's name: _____

Grade: _____ **City:** _____

County: _____

My Legislative District Number is: _____

My State Senator is: _____

My General Assembly Members are: _____

Contents

The New Jersey State House.....	2
Roaming the Dome	3
Our State Seal	4
State Symbols	5
Color the Carpet	6
Our State Map.....	8
County Questions	9
Know Your Legislature	10
How Laws are Made	12
Capitol Crossword.....	14
Laws About Things	15
The Language of Lawmakers.....	16
About Our Government	17
Help Bill Become Law.....	18
Get Involved!	19
Become a Legislator	20
Answer Pages	21

The New Jersey State House

What's missing from the New Jersey State House?
Connect the dots and find out!

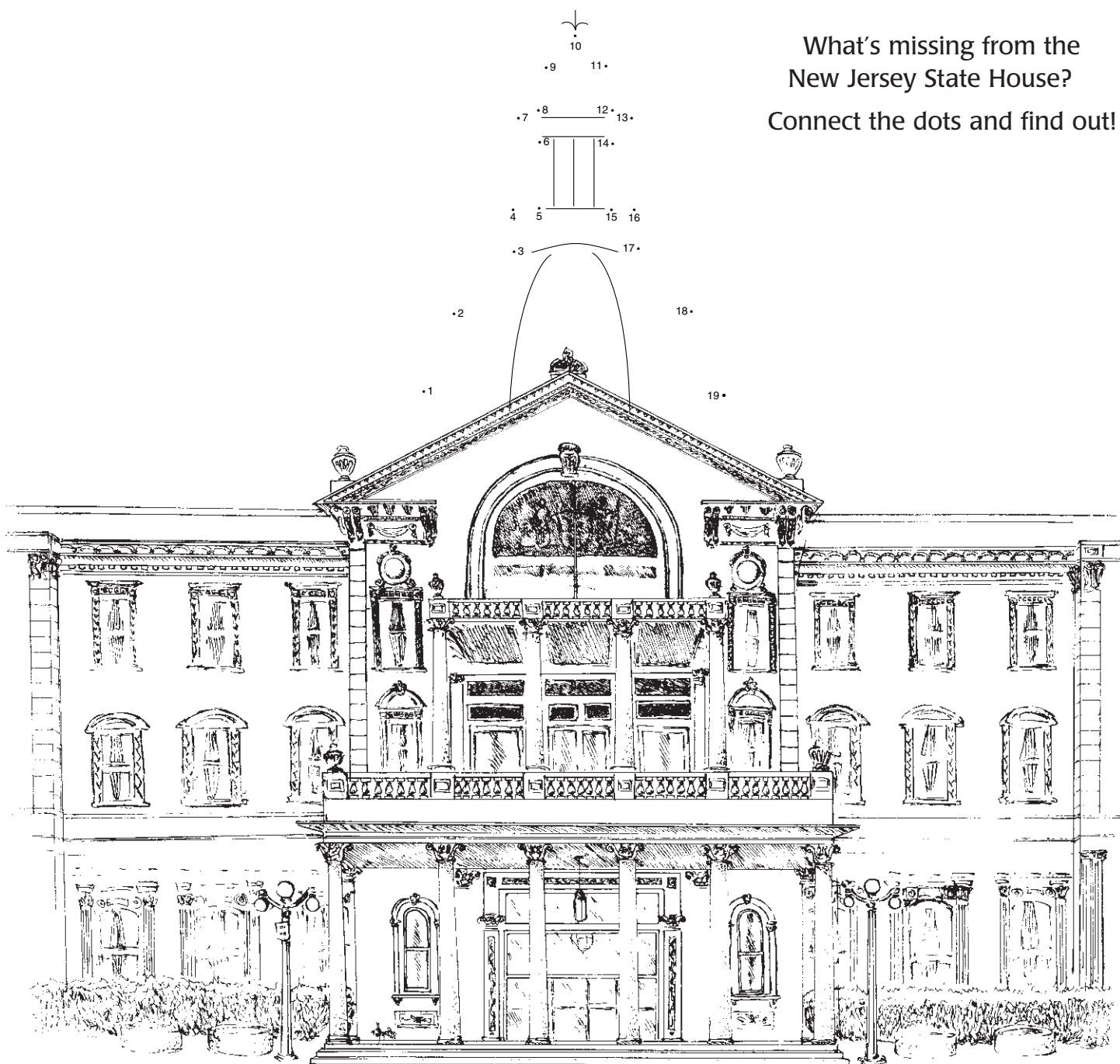

The State House was originally built in 1792 by Jonathan Doane. The building looked very different from the State House of today. It was a simple rectangular building of rubblestone with a bell tower. According to legend, the bell was rung to call people to the State House.

As the government's duties grew, so did the State House. Many additions were made over the years. Today, the Governor's offices are in the front of the building while the Legislature works in the restored rear wings.

Roaming the Dome

The dome is a well-known symbol of our state government. Over the years, the dome became damaged and repair was needed. The state recently restored the dome to its former glory. See if you can answer these dome questions.

1. The Dome ceiling is 105 feet above the floor of the Rotunda. If all the students in a class are 5 feet tall, how many students would you need to stand on top of each other in order to touch the ceiling?

2. School children helped raise about \$40,000 for the repairs. This money was used to replace the gold leafing on the Dome. Exactly how many dimes were collected to raise this money?

3. It takes 4 pieces of gold leaf to cover 1 square foot of the dome. If the dome is 3,000 square feet, how many pieces of gold leaf are needed to cover the entire dome?

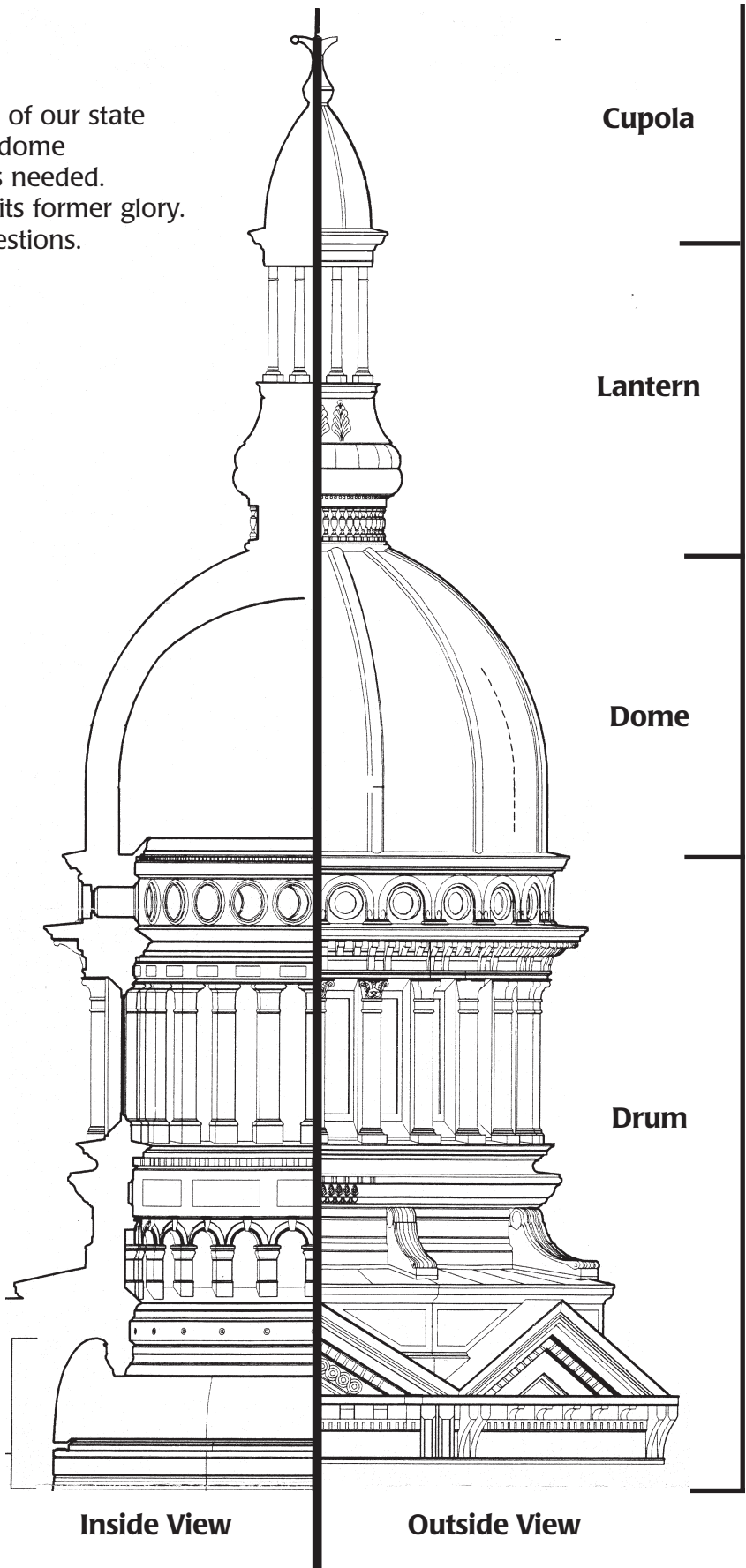

(answers on page 21)

Our State Seal

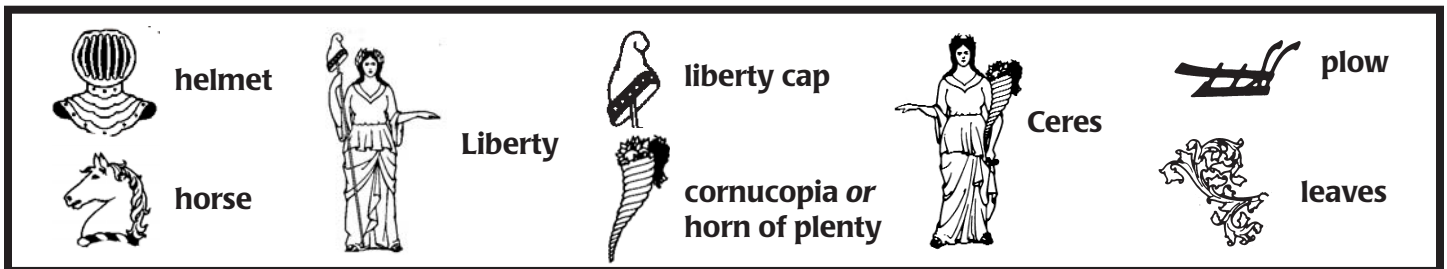

New Jersey's State Seal was designed by Francis Hopkinson for our new state in the year 1777. Each of the Seal's symbols stands for something important about New Jersey.

The helmet with its crest of a horse's head indicates that New Jersey is a sovereign State – meaning that we make laws for ourselves.

The woman on the left is Liberty. Liberty means freedom. She holds a staff topped by a liberty cap, an important symbol of freedom. The woman on the right is the Roman goddess Ceres, who represents agriculture and prosperity. She grasps a cornucopia or "horn of plenty."

The three horse-drawn plows on the shield, the horse's head on the helmet and the swirls of leaves also symbolize New Jersey's farming tradition. The scroll at the bottom bears the motto

"L_____ and P_____" and the date _____, the year New Jersey became a state.

(answers on page 21)

State Symbols

Our state has several official symbols that represent many of the things that are special about New Jersey. The Legislature chose the first official symbol, the state flower (the violet), in 1913. Since then, eight more symbols have been added.

Draw lines to connect the picture of each symbol to its name. The year after each name tells you when the New Jersey Legislature adopted the symbol. (answers on page 21)

1. **Violet**,
State Flower, 1913
2. **Eastern Goldfinch**,
State Bird, 1935
3. **Red Oak**,
State Tree, 1950
4. **Honey Bee**,
State Insect, 1974
5. **Horse**,
State Animal, 1977
6. **Square Dance**,
State Folk Dance, 1983
7. **Hadrosaurus Foulkii**,
State Dinosaur, 1991
8. **Brook Trout**,
State Fish, 1991
9. **Knobbed Whelk**,
State Shell, 1995
10. **A.J. Meerwald**,
State Tall Ship, 1998
11. **Blueberry**,
State Fruit, 2004

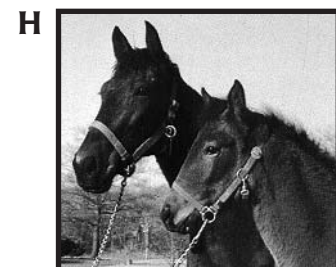
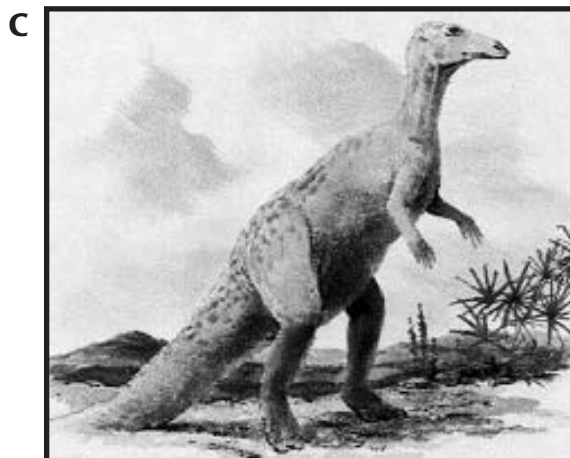
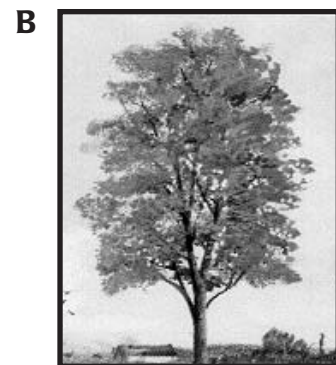

Color the Carpet

Here is a drawing of part of the carpet that covers the floor of the General Assembly chamber in the State House. It was designed by artists and made by skilled workers for our capitol. The rug contains pictures of some of New Jersey's important symbols.

Can you identify each of the items and color them appropriately?

Fill in the blank spaces below to help you identify the state symbols, then use the color guide to help you choose the right colors for your picture of this carpet.

(answers on page 21)

This mighty tree has acorns and green leaves that turn red in the fall:

r o

This state bird is the same color as the gilded State House dome:

g

This state insect uses flowers to make a sweet, sticky syrup:

h b

Spring is the time to see this small purple flower:

v

Color Codes

B	=	Blue
G	=	Green
Bk	=	Black
V	=	Violet
Br	=	Brown
Y	=	Yellow



Our State Map

Unscramble the names of the New Jersey counties and write them on the lines provided. To help you, a list of the counties is provided on the next page. (answers on page 21)

MORRIS

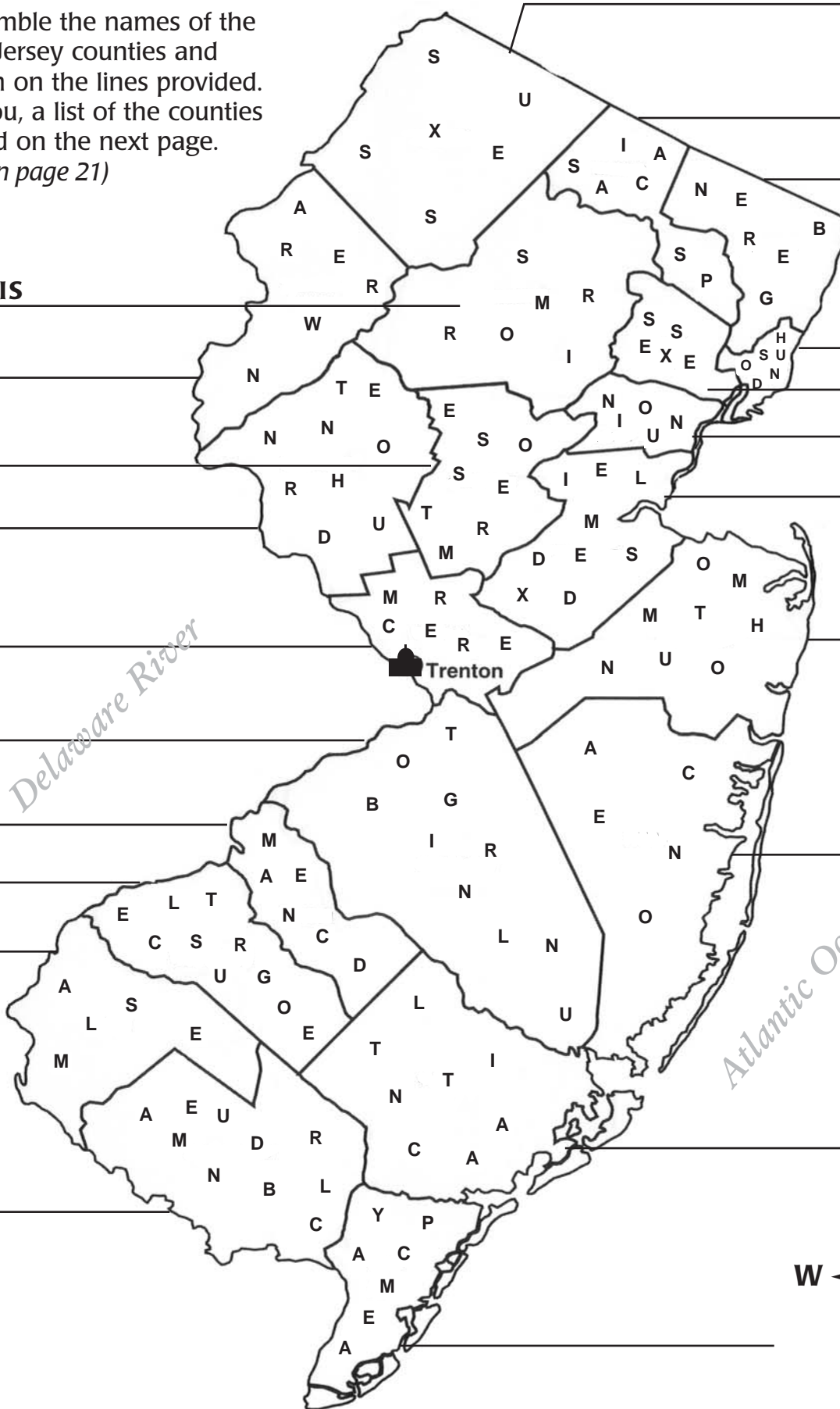

County Questions

ATLANTIC
BERGEN
BURLINGTON
CAMDEN
CAPE MAY
CUMBERLAND
ESSEX

GLOUCESTER
HUDSON
HUNTERDON
MERCER
MIDDLESEX
MONMOUTH
MORRIS

OCEAN
PASSAIC
SALEM
SOMERSET
SUSSEX
UNION
WARREN

1. How many counties are there in New Jersey? _____
2. Our state capitol is located in the county of _____.
3. In what county do you live? _____
4. How many counties border the Delaware River? _____
5. How many counties border the Eastern side of the State? _____
6. Which two counties border both the Atlantic Ocean and Delaware River? _____
7. What is the northernmost county? _____
8. What is the southernmost county? _____
9. How many counties are entirely surrounded by other counties? _____
10. Which two counties were named for the body of water that they border? _____

(answers on page 21)

Did you know...

- ...the name "Passaic" comes from a Native American language meaning "valley" or "place where land splits"?*
- ...Mercer and Warren Counties were named for famous Revolutionary War generals?*
- ...there were only 13 counties in New Jersey before 1776?*
- ...Trenton was originally selected as the capital of the United States in 1784?*
- ...Hudson County was named for the famous explorer Henry Hudson?*

Know Your Legislature

What is the Legislature?

The Legislature is the branch of government that makes new laws and changes old ones.

Our State Legislature makes laws only for New Jersey. It is made up of 120 members elected from 40 regions within the state called legislative districts. These men and women represent the views and concerns of the people in their parts of the state.

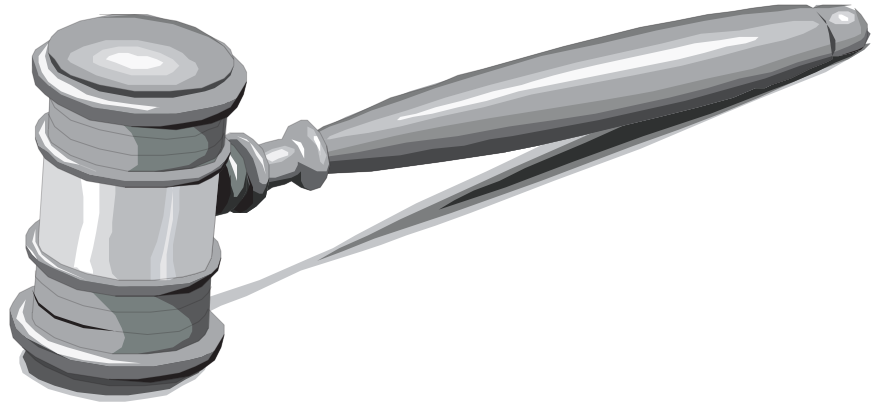

What are Houses?

The New Jersey Legislature is divided into two parts, called "Houses." The Houses of the New Jersey Legislature are the Senate and the General Assembly. There are 40 Senators and 80 General Assembly members who are elected by the voters in their legislative districts.

A legislature that consists of two houses is called "bicameral." One state in our country has only one lawmaking unit, which means its legislature is "unicameral." Can you name the state?

What are political parties?

The members of the two Houses are divided into groups or teams, called "political parties." The two major parties are the Democrats and the Republicans. The group having the largest number of members is called the "majority party." The other group is the "minority party."

The Democratic Party mascot is the donkey.



The Republican Party mascot is the elephant.

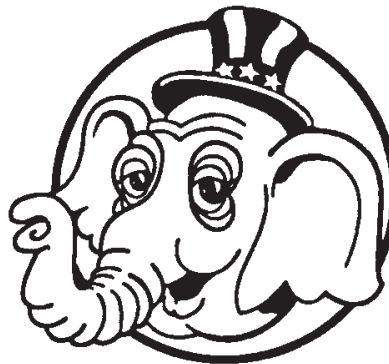

Know Your Legislature

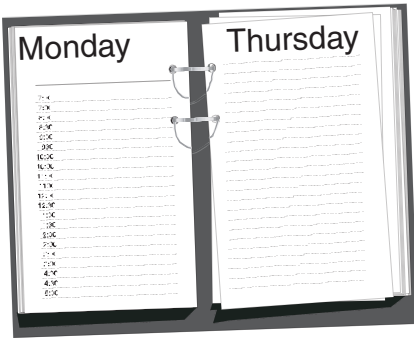

When does our Legislature meet?

The Houses usually meet on Mondays and Thursdays all year long. Meetings to vote on proposed laws, called "bills," are "voting sessions." The Legislature meets in the State House in Trenton, New Jersey's capital city. Most years, both Houses take a break or "recess" during July and August.

Who can be a legislator?

A State Senator must be at least 30 years old and must have lived in New Jersey for at least four years. A member of the General Assembly must be at least 21 years old and must have lived in the state for at least two years. Both must live in their legislative districts for one year before the election.

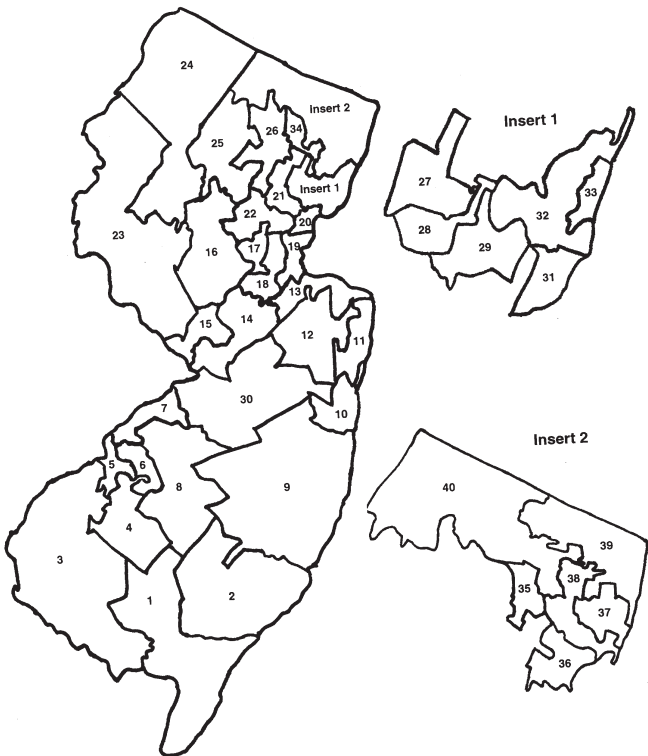
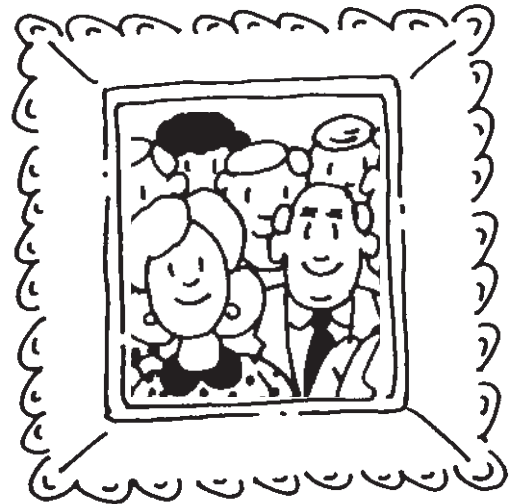

What are legislative districts?

New Jersey is divided into 40 regions called legislative districts. The residents of each district elect one Senator and two General Assembly members. Each legislative district has about the same number of people in it, so each legislator represents about the same number of people.

New district boundary lines are drawn every 10 years after an official count called a "census" has been taken of the people and where they live. The shapes of the districts may be changed to reflect changes in the population. City districts are usually small because many people live in a small area. Suburban and rural legislative districts may be very large, which shows residents live farther apart.

Bill's Journey to



Any Senator or General Assembly member may propose or sponsor a new law. Ideas for laws can come from many sources, such as citizens, interest groups, public officials or the Governor.

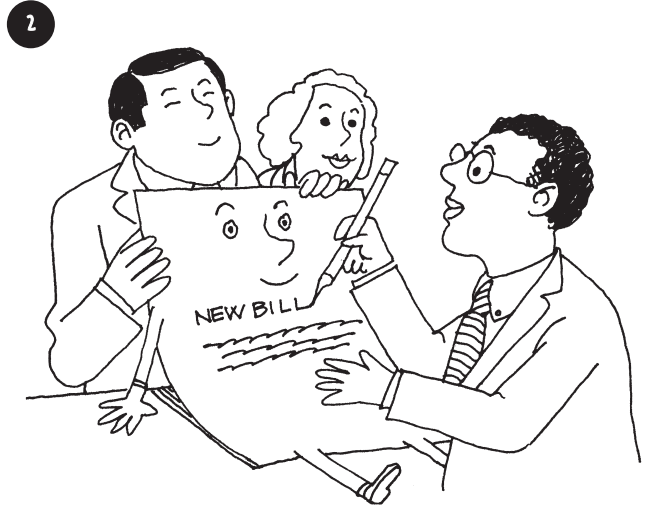

At the legislator's direction, the idea is written as a bill. The legislator may ask other legislators to become co-sponsors.



If the committee approves the bill, it is reported back to the House where it began, and its title is read again. This is the bill's second reading.

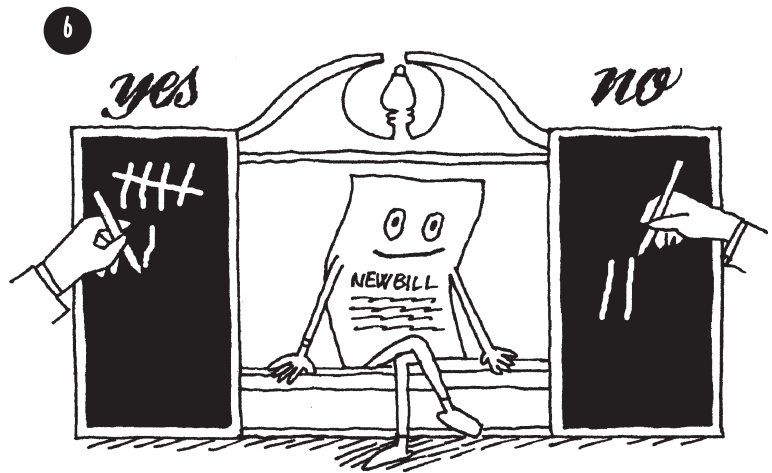

When scheduled by the Senate President or General Assembly Speaker, the bill's title is read for the third time, and it is debated and voted on. A bill passes if it receives a majority of votes (at least 21 in the Senate or 41 in the General Assembly).

Becoming a Law

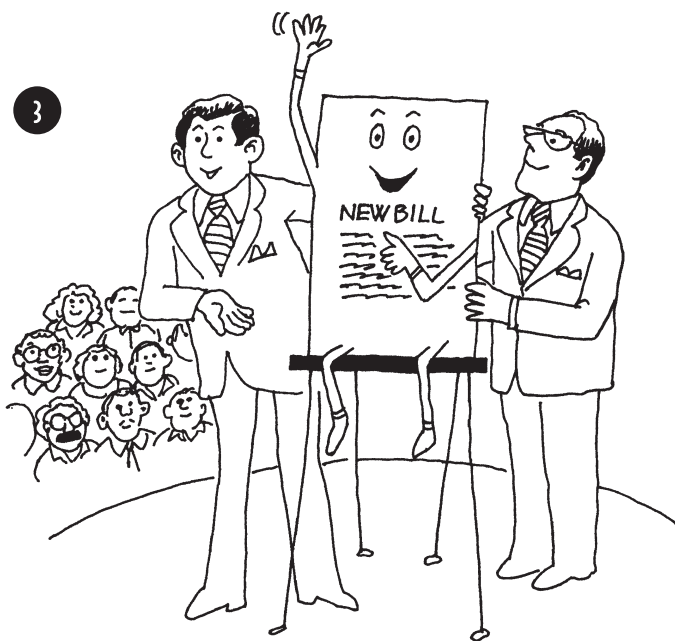

The bill is introduced when the Senate Secretary or General Assembly Clerk reads the bill's number, sponsor and title aloud during a legislative session.

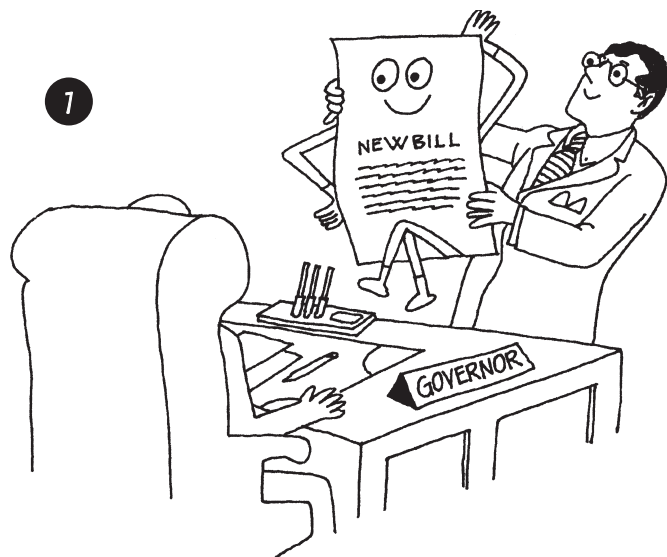

The bill follows a similar path of first reading, committee consideration, second reading, third reading and final passage in the second House.

After both Houses agree on the bill, it is sent to the Governor.
In most cases, the bill becomes law when signed by the Governor.



The bill is usually sent to a committee which studies it and makes changes, if needed.

These changes are called amendments.

Committees have open meetings where the public may speak about the bill.

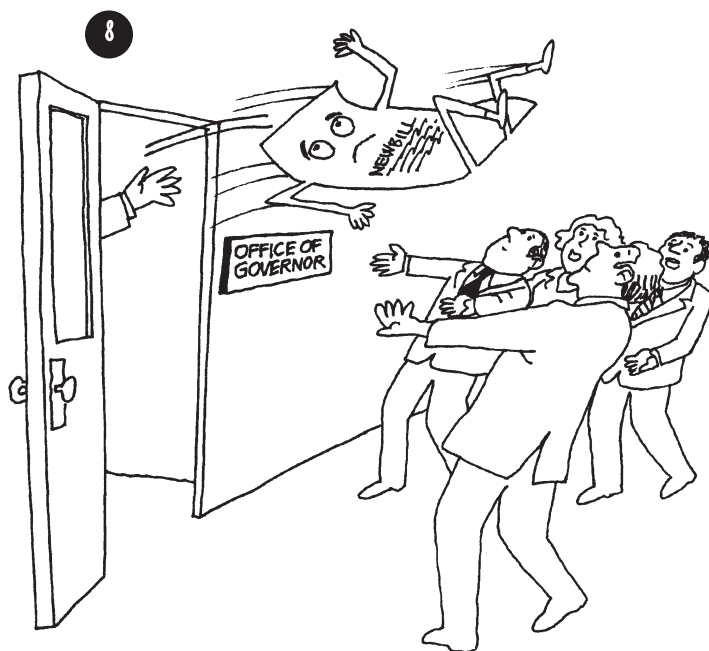

If the Governor rejects the bill, it is called a veto.

Sometimes, the Governor will ask the Legislature to make changes to the bill.

The Legislature may make the Governor's changes.

It is also possible for the Legislature to pass the vetoed bill in its original form with a 2/3 majority vote in both Houses. This is called overriding the veto.

Capitol Crossword

Choose the right word to complete each sentence and then use the words to fill in the puzzle. (answers on page 21)

Assembly
bill
Capitol
district
elected
Monday
nay
Senate
veto

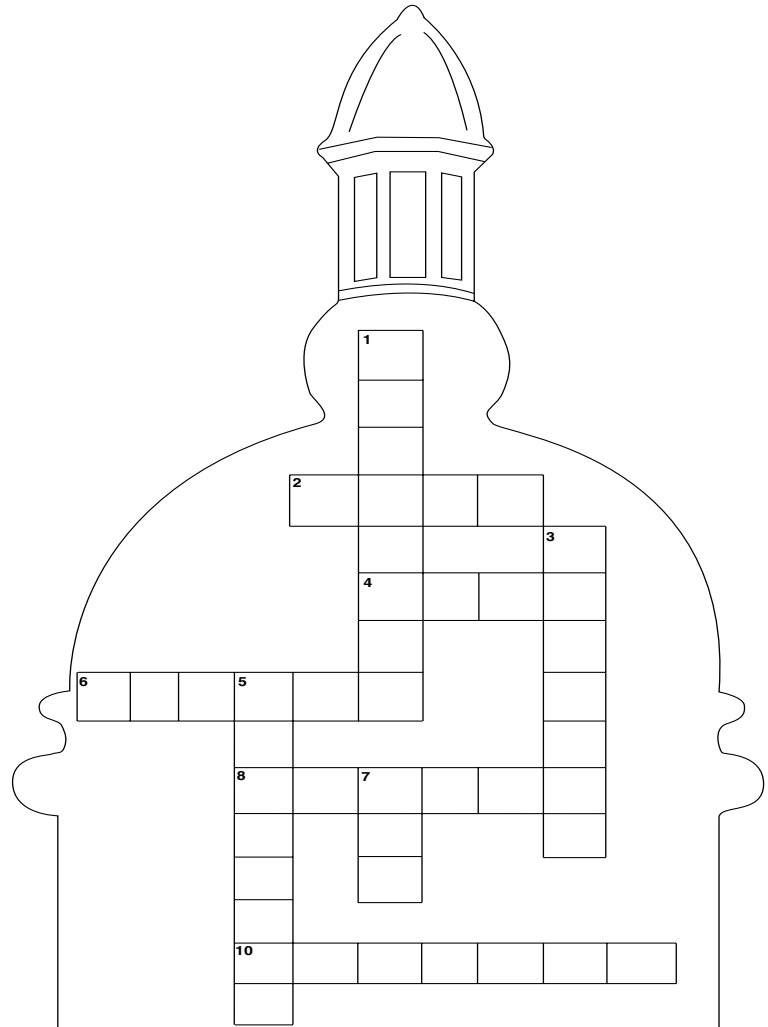

- Across:**
- 2. When the Governor rejects a bill, it is called a _____.
 - 4. A _____ that is signed by the Governor becomes a law.
 - 6. The Legislature will typically meet on _____ and Thursday of each week.
 - 8. A Senator is a member of the _____.
 - 10. The _____ is the building where our Governor and Legislature work.

- Down:**
- 1. The General _____ is one House of our Legislature.
 - 3. Members of the Legislature are _____ by the citizens of the state.
 - 5. Each _____ is represented by one Senator and two members of the General Assembly.
 - 7. When voting, the legislators vote yea for yes and _____ for no.

Laws About Things

All of us are affected by laws, and the New Jersey Legislature makes laws about many things. Some may be familiar to you and others may be a surprise.

The list below names a few things that are affected by our state laws. Find all the words in the puzzle. (Hint: Some of the words may appear backwards and diagonally. Answers on page 22.)

- helmet
- jet ski
- seafood
- taxes
- horses
- museum
- cars
- tractors
- beach
- train
- music
- water

H	F	B	H	A	I	S	O	T	C
Q	E	K	I	O	N	I	A	R	T
I	R	L	A	A	R	Y	E	M	R
K	C	E	M	T	A	S	B	U	A
S	I	Z	T	E	E	V	E	E	C
T	S	E	X	A	T	R	A	S	T
E	U	X	F	B	W	E	C	U	O
J	M	O	K	I	N	T	H	M	R
A	O	H	C	G	C	A	R	S	S
D	P	J	M	U	S	N	P	M	I

How many of these laws affect you? List them below.

The Language of Lawmakers

Definitions

AMEND: To change a bill.

Bill: An idea for a new law.

Committee: Group which is asked to do a special job. For example, legislative committees study suggestions for new laws.

Constituents: Members of a group represented by an elected official.

Debate: People discuss varying opinions on an issue.

Law: A rule that all people of a society must obey.

Legislator: An elected government representative who speaks for others.

Vote: To signal a choice.

Find out what all the buzz was about when a group of second-grade students wanted New Jersey to have a state bug. Use the words to the left to fill in the blanks and finish the story. (answers on page 22)



Mrs. Zuzov always encouraged her students to take an interest in government. In 1973, her second-grade class at Sunnybrae School had been reading about how Maryland had the butterfly as its state bug. The students decided that New Jersey should have one also, so they wrote a letter to Assemblyman Francis McManimon, a 1. _____ from their district, telling him about their idea. Assemblyman McManimon visited his young 2. _____ to hear more about their idea. There were many suggestions about which bug to select, so with the help of the Assemblyman the students made a compromise and decided that the Honey Bee would be their choice. He then promised the students that if he was reelected, he would introduce a 3. _____ to the Legislature proposing the Honey Bee as the State Bug.



After the Assemblyman won reelection, the students contacted him again and reminded him of his promise. The students visited the State House several times to check on the progress of their idea. A decision was made by the State Government 4. _____ to move the bill to the Assembly for 5. _____. During the Assembly's discussion, the Legislators chose to 6. _____ the bill by changing the name of it from "State Bug" to "State Insect." When the discussions were finished, the Legislators took a 7. _____ to decide if the bill would move on to the Governor.

On July 20, 1974, Governor Brendan Byrne, surrounded by teachers, parents and students dressed in bee costumes, signed the bill into 8. _____. The Honey Bee had become New Jersey's official State Insect. Mrs. Zuzov and her students were very proud that they had played a part in their State's legislative process.



About Our Government

Fill in as many of the blanks below as you can. The number of spaces tells you how many letters are in the word. If you get stuck, look at the key at the bottom of the page.
(answers on page 22)

New Jersey's _____ establishes the state's govern-
ment and all our laws. Our government has _____ main branches. They are
the _____, the _____ and the
_____ branches. The _____ makes
the laws for all New Jersey, based on the requirements and the limits in the constitution.
There are two groups, or Houses, in the Legislature – the _____ and the
_____. The executive branch of govern-
ment carries out the _____ made by the Legislature. At the head of this branch is
the _____. The judicial branch of government is made up of the
_____. This system of courts and _____ considers the facts
in trials, interprets the laws, settles disputes between citizens, and imposes penalties on
people who break the law.

A B C D E F G H I J K L M N O P Q R S T U V W X Y Z
1 2 3 4 5 6 7 8 9 10 11 12 13 14 15 16 17 18 19 20 21 22 23 24 25 26



Help Bill Become Law



Bill needs help to become a law! Go through the maze and show Bill the right path to take! (answers on page 22)

START HERE

Proposal: a law begins with an idea

Bill Draft: the idea is written in proper form

First Reading: the bill is introduced in the sponsor's House during a session and sent to a committee

Committee Action: the committee approves the bill and sends it on

Second Reading: after committee approval, the bill is given a second reading

Committee Review: the committee studies the bill and may make changes

Third Reading and Final Passage: the bill passes if a majority votes for it

Governor's Action: the governor may sign the bill into law or veto it

Veto Override: if the bill is vetoed, it may still become law by two-thirds vote of the Senate and the Assembly

Final Passage: the bill passes the second House in the same form

Second House: the bill must go through the same process here

FINISH

Bill Becomes A Law!



Get Involved!



Look, listen and learn!

The best way to get involved is to know what's going on. Once you hear everyone's point of view, then it's easier to make up your own mind.

Vote!

All citizens have the right to vote. Each New Jersey resident votes to elect one State Senator and two General Assembly members, who then make laws for us. To vote, you must be at least 18 years old and registered with the Board of Elections in your community.

Even though you may not be old enough to vote, you can still make your voice heard. Here's how:

Talk to someone who CAN vote!

Share your feelings and ideas with your parents, neighbors, friends, relatives and community leaders.

Write a letter, call or E-mail your legislator!

Tell your lawmakers how you feel about your community and state.

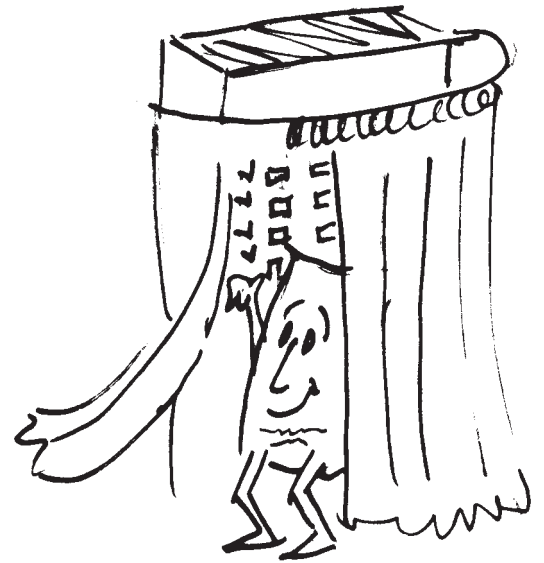

Join forces!

Work with other people or groups who share your thoughts. Tell everyone to contact their legislators.

Show your support!

A petition is like a special request signed by many people and shared with your lawmakers. Citizens may also gather at public events, such as rallies, to show support for issues.

Do you have any ideas for new laws?

Are there things you want to see changed in your community? Write down two ideas that you have for laws.

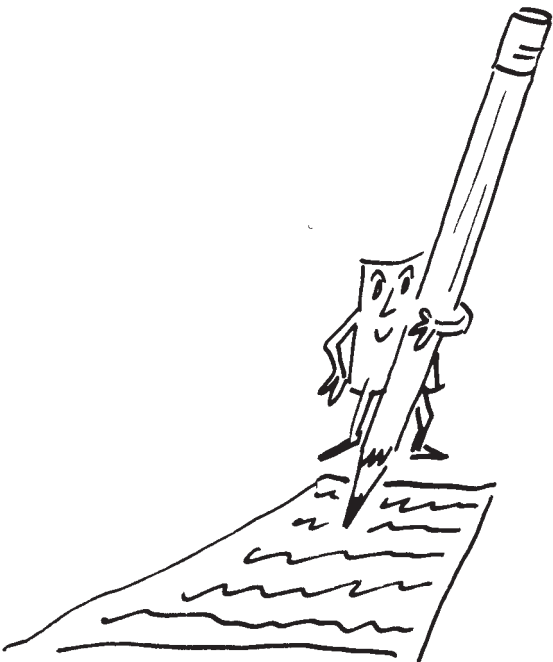

Become a Legislator

New Jersey needs future legislative leaders! Remember, you must be at least 21 years old to run for office. You may be too young to run, but it's never too early to start your campaign! That means telling lots of people about yourself and your ideas.

Buttons are a good way to get your name around! Below are some sample buttons.

Try making your own and hold a pretend election in your classroom. Remember, everyone gets to vote for one Senator and two General Assembly members. Good luck!

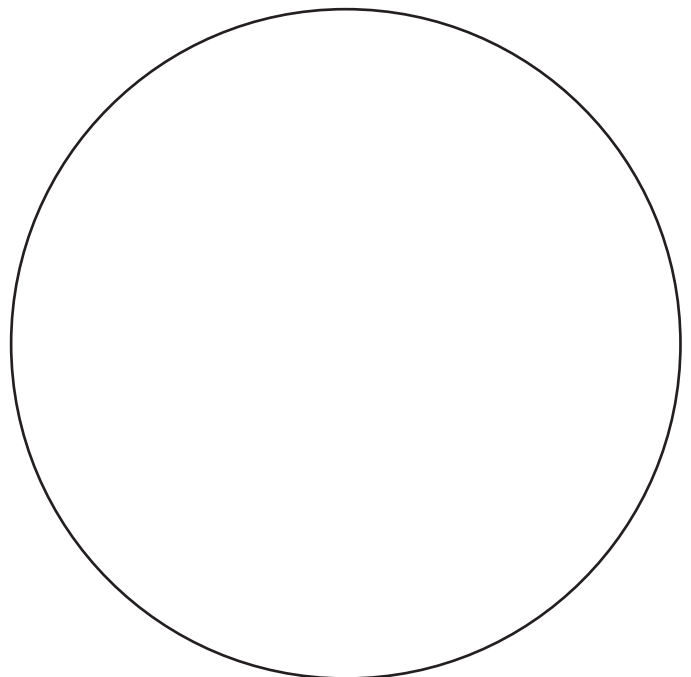
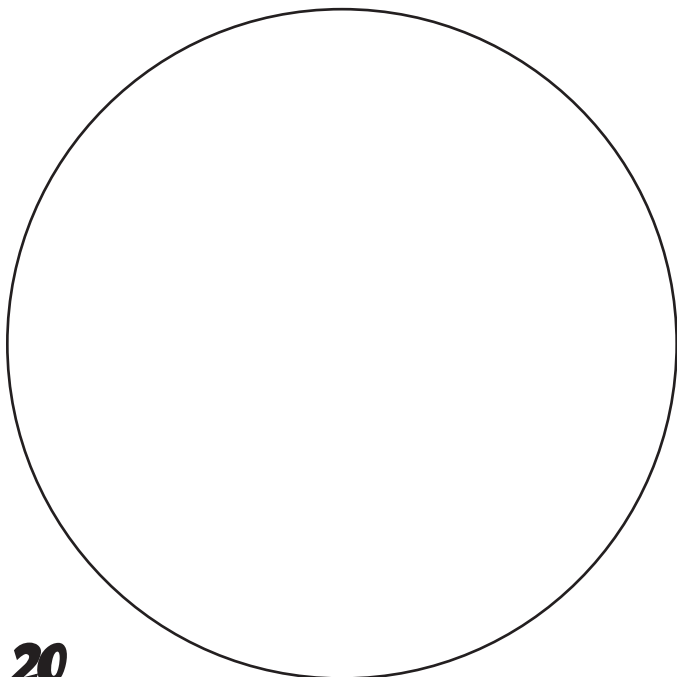
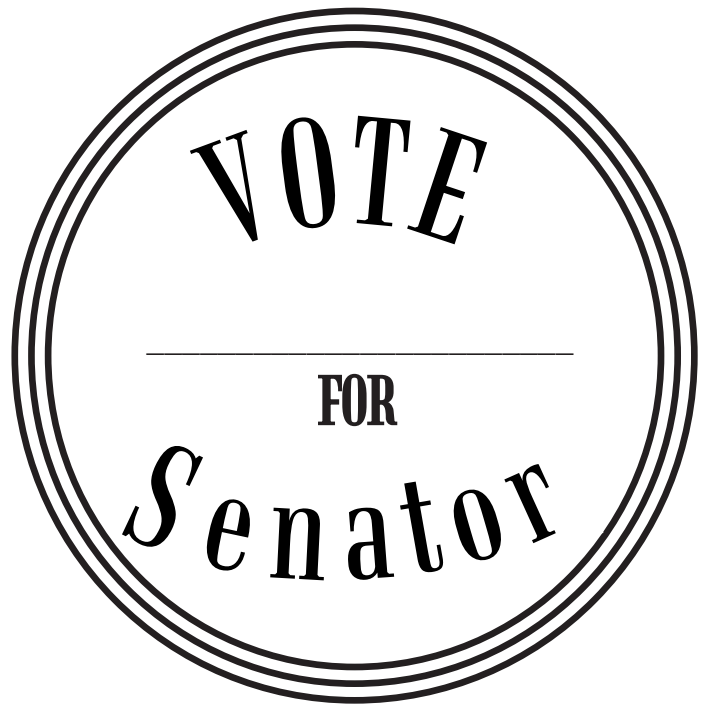

Answers

Page 2

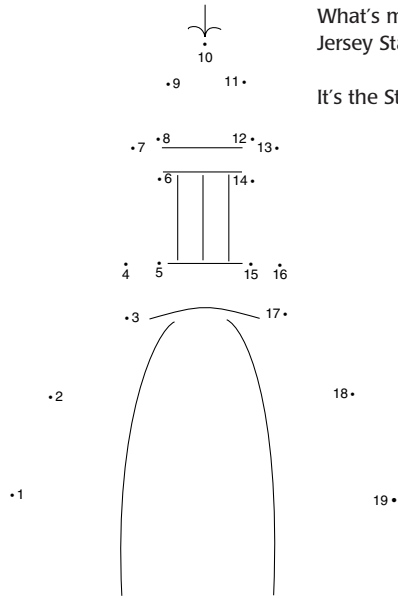

What's missing from the New Jersey State House?

It's the State House D.O.M.E.

Page 3

- 21
- 400,000 dimes collected
- 12,000 pieces of gold leaf

Page 4 Liberty, Prosperity, 1776

Page 5

- D
- G
- B
- I
- H
- F
- C
- A
- E
- K
- J

Page 6 red oak, goldfinch, honey bee, violet

Page 9

- 21
- MERCER
- 10
- 9
- BURLINGTON AND CAPE MAY
- SUSSEX
- CAPE MAY
- 3
- ATLANTIC and OCEAN

Page 10 Nebraska

Page 8

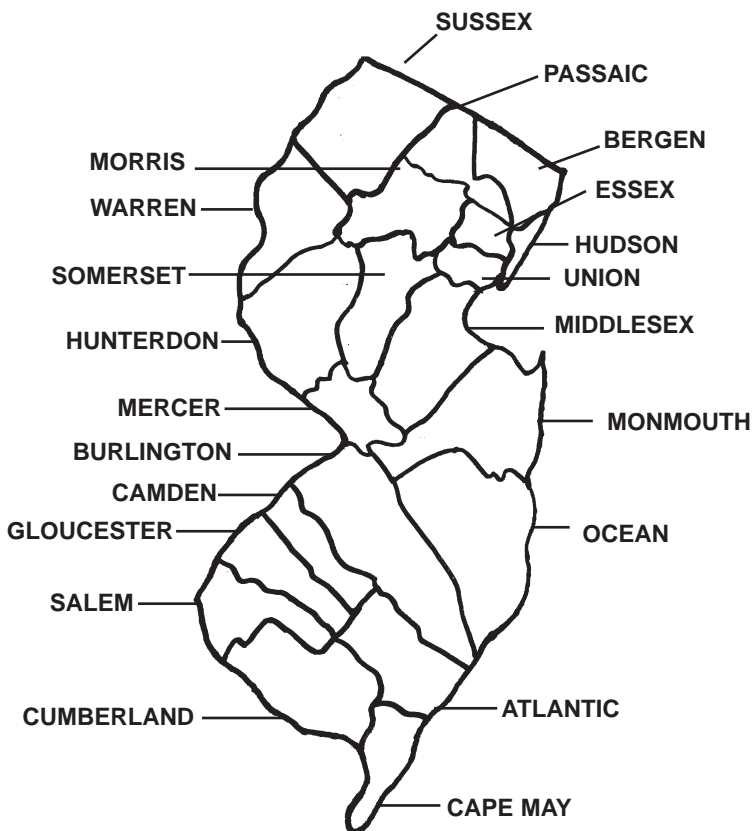

Page 14

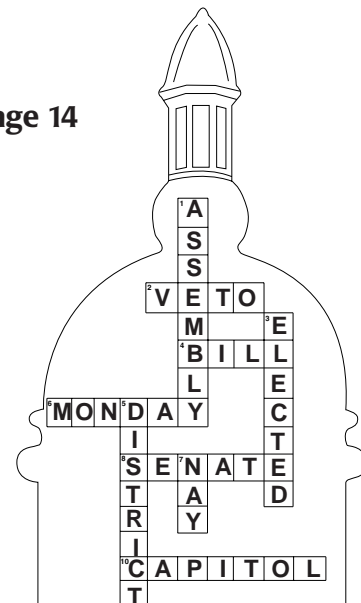

Answers

Page 15

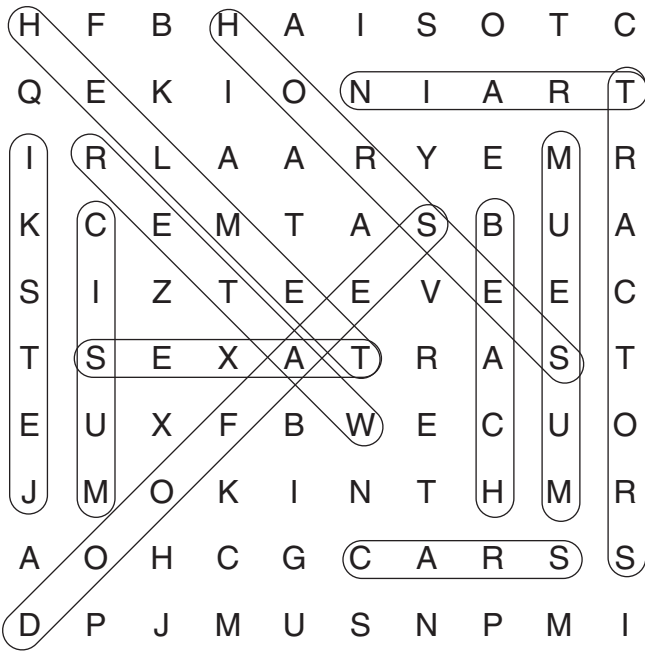

Page 16

1. LEGISLATOR
2. CONSTITUENTS
3. BILL
4. COMMITTEE
5. DEBATE
6. AMEND
7. VOTE
8. LAW

Page 17

New Jersey's **CONSTITUTION** establishes the State's government and all our laws. Our government has **THREE** main branches. They are the **LEGISLATIVE**, the **EXECUTIVE**, and the **JUDICIAL** branches. The **LEGISLATURE** makes the laws for all New Jersey, based on the requirements and the limits in the constitution. There are two groups, or Houses, in the Legislature – the **SENATE** and the **GENERAL ASSEMBLY**. The executive branch of government carries out the **LAWS** made by the Legislature. At the head of this branch is the **GOVERNOR**. The judicial branch of government is made up of the **COURTS**. This system of courts and **JUDGES** determines the facts, interprets the laws, settles disputes between citizens, and imposes penalties on people who break the law.

Page 18

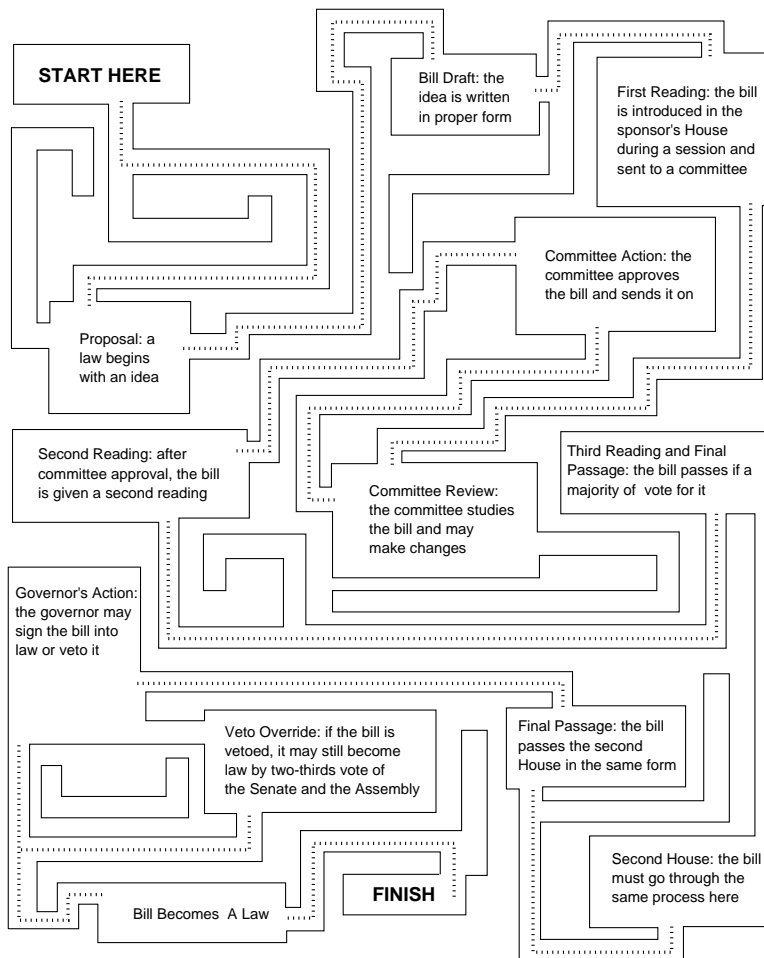



Prepared By:
The Office of Legislative Services
Office of Public Information
State House Annex, PO Box 068
Trenton, New Jersey 08625-0068
www.njleg.state.nj.us